



PETROL LAWN MOVER RIDER
RAC6625PR / RAC6625SDPR

USER GUIDE

CAUTION: Read the instructions before using the machine!

CONTENTS

1. SAFETY INSTRUCTIONS.....	3
2. INTENDED USE.....	10
3. YOUR PRODUCT.....	12
4. ASSEMBLY.....	13
5. BEFORE USE.....	18
6. OPERATION	19
7. MAINTENANCE AND STORAGE.....	24
8. TROUBLESHOOTING.....	34
9. DECLARATION OF CONFORMITY.....	36
10. WARRANTY.....	37
11. PRODUCT FAILURE.....	38
12. WARRANTY EXCLUSIONS.....	39

1. SAFETY INSTRUCTIONS

DANGER: This machine was designed to be operated in accordance with the safe operation practices outlined in this manual. As with any type of power equipment, operator error or carelessness can result in serious injury. This machine is capable of amputating fingers, hands, toes, and feet, and can also throw objects with great force. Failure to adhere to the following safety instructions could result in serious injury or even death.

1.1 GENERAL SAFETY REGULATIONS

Warning! Read carefully before using the machine.

Training

- Read the instructions carefully. Be familiar with the controls and proper use of the equipment.
- Never allow children to use this machine. Local laws may restrict the age of the user.
- Never mow while people, especially children, or animals are nearby.
- Keep in mind that the operator or user is responsible for accidents or risks that may occur to other persons or their properties.
- If necessary, have training with an experienced person in order to use in a safe way this machine.
- Do not carry passengers. All drivers should seek and obtain professional and practical instructions. Such instructions should emphasise:

-the need for care and concentration when working with ride on machines;

-you cannot use the brake to regain control of a ride-on machine sliding down a slope.

The main reasons for loss of control are:

-insufficient wheel grip;

-over speeding;

-inadequate braking;

-the type of machine is unsuitable for its task;

-unawareness of the effect of ground conditions, especially slopes.

Preparation

- During mowing, always wear safety shoes and long pants. Do not use the equipment barefoot or wearing sandals open.
- Carefully inspect the area where equipment is being used by removing all objects that may be affected by the machine.
- **WARNING - Gasoline is extremely flammable.**
 - Add fuel before starting. Do not remove the fuel tank cap while the machine is running or when it is hot.
 - If the fuel has spilled or leaked, do not attempt to start the machine but move the machine away from the leakage area and avoid creating a source of ignition until the gasoline vapors has dissipated.
 - Refuel only outside and do not smoke during refueling.
 - Store fuel in tanks specifically designated for this purpose.
 - Replace the fuel tank or the defective gasoline plug securely.
- Replace defective mufflers.
- Before use, always inspect visually that the blades, blade assembly and blade lock are not worn or damaged. Replace blades and blade assemblies that are not in good condition to maintain balance. Contact the manufacturer or your dealer in order to have a list of recommended blades. Non-recommended blades can give a risk of malfunctions, injuries and accidents.
- The blades must be balanced to ensure proper operation and to be able to work safely.

Operation

- In case of lack of knowledge or first use of this product, we recommend that you have a formation/ training with a professional or an experienced person.
- Before mowing, remove all foreign objects (such as stones, toys, sticks and wires) from the grass that can be propelled by the machine.
- Do not use the machine in a confined space or hazardous carbon monoxide emissions can be

collected.

- Mow only under daylight or under good artificial light. Good visibility must always be ensured.
- Warning: Do not use the machine where there is a risk of lightning.
- Warning: do not use of the unit while being tired, ill or under influence of alcohol or other drugs.
- Alcohol, drug, as well as illness, fever and fatigue affect your ability to respond. Do not use this machine in such circumstances.
- Keep children and pets at a safe distance while using the machine.
- The lawnmower shall not be operated without either the entire grass catcher or self-closing discharge opening guard in place.
- Warning: there is a danger of moving blade assemblies during adjustment.
- Use the machine only for the intended use as described in manual. Misuse will create accidents and damages.
- Before starting the engine, disengage the blades and shift into neutral.
- **Do not use on slopes of more than 15°(25%).**
- Remember there is no such thing as a “safe” slope.
- Travelling on grass slopes requires particular care. To guard against overturning:
 - -do not stop or start suddenly when going up or downhill;
 - -engage the drive slowly and always keep the machine in gear, especially when travelling downhill;
 - -machine speeds should be kept low on slopes and during tight turns;
 - -stay alert for humps and hollows and other hidden hazards;
 - -never mow across the face of the slope.
- Stop the blade from rotating before crossing surfaces other than grass.
- Never use the machine with damaged guards, or without safety protective devices in place.
- Do not change the motor configuration or increase the speed. Operating the engine at excessive speed can increase the risk of personal injury.
- Before leaving the driving seat:
 - -lift emergency stop switch and lower chassis position
 - -go into neutral and apply the parking brake;
 - -stop the engine and remove the ignition key (in the electric start models).
- Lift the emergency stop switch, turn off the engine and remove the start key
 - -before clearing blockages or unclogging chutes;
 - -before cleaning, checking or working on the machine;
 - -after striking a foreign object. Inspect the machine for any damage and make repairs before restarting and operating the machine;
 - -if the machine starts to vibrate abnormally (inspect it immediately).
- Disengage the power when transporting or whenever it is not in use.
- Stop the engine and disengage the power:
 - -before refuelling;
 - -before removing the grass-catcher.
- Reduce the throttle setting before stopping the engine.
- Park safely the tool before leaving it. The tool must be switched off.
- Warning: be careful about exhaust gas. Do not inhale them and do not expose people to these gases.
- To avoid health issues, limit the time of operation. Take enough rest. Exposure to noise and vibrate can have bad consequences on health.
- **WARNING:** There is a danger about moving blade assemblies. Always handle blades when they are in a complete stop and wear protective gloves.
- The blade stopping device must always work. If the blade does not stop after stopping the machine and the devices are damaged, the machine should be taken to a qualified service for inspection.

Maintenance and storage

- Check and tighten all bolts, bolts, and screws to ensure that the equipment is in safe operating condition.
- Never keep the mower with gasoline in the tank in a building or vapours can cause a bright

flame or spark.

- Allow the machine to cool before storing it in an enclosed area.
- To reduce the risk of fire, keep the machine clean without grass, without grease, the muffler and the engine cools, disconnect the battery if necessary and empty the fuel tank
- Check the grass catcher frequently, its condition or deterioration.
- Replace worn and damaged parts for safety.
- If the fuel tank is to be drained, it must be made outdoors.
- The machine safety systems or features shall not be tampered with or disabled.
- When the machine is to be stored or left unattended, lower the cutting check.
- Always bring maintenance.
- Improper maintenance can reduce life of the tool and create accident and damages.

Residual risks

Even if you use this product in compliance with all safety requirements, the potential risks of injury and damage remain. The following hazards may arise in the structure and design of this product: There are risks of injury and property damage due to attachments or broken the sudden impact of hidden objects when using cutting.

There are risks of injuries and accidents caused by flying objects.

Prolonged use of this product exposes the operator to vibrations and can produce so-called "white finger" disease. To reduce the risk, wear gloves and keep your hands warm.

If any of the symptoms of "white finger syndrome" occur, seek immediate medical attention.

Symptoms of "white finger" include numbness, loss of sensitivity, tingling, pain, loss of strength, colour changes or skin condition. These symptoms usually appear on the fingers, hands or wrists.

Risk increases at low temperatures.

A long exposition to noise can affect the health of the operator. A hearing protection must be always used when operating the tool. The operation of the tool must be limited, and some rest must be taken between two sessions (e.g. 10min of operation and 20min of rest).

1.2 SPECIAL SAFETY INFORMATION FOR THE RIDER

PREPARATION BEFORE OPERATING

- 1) Before using the tractor, conduct a thorough inspection of the area. Remove any stones, sticks, wire, bones, toys, or other foreign objects that could potentially be picked up and thrown by the blade(s). It is important to note that thrown objects have the potential to cause significant personal injury.
- 2) In order to minimize the risk of blade contact or injury caused by thrown objects, it is essential to maintain a safe distance of at least 75 feet (23 meters) between the tractor and any assistants while it is in operation. Ensure that bystanders, children, and pets remain indoors during tractor operation. If anyone enters the operating area, promptly stop the tractor to prevent any potential accidents.
- 3) Stay mindful of the direction of the tractor's discharge and make sure not to aim it towards anyone. For your safety, it is crucial to wear safety glasses or safety goggles at all times while operating the tractor or when making adjustments or repairs.
- 4) This is necessary to protect your eyes from potential harm caused by ricocheting objects, which can lead to serious eye injuries.
- 5) Ensure that you wear sturdy work shoes with rough soles, as well as close-fitting slacks and shirts. Loose-fitting clothing, jewelry, and long hair pose a risk of getting caught in moving parts, so it is important to avoid them. Never operate the tractor barefoot or in sandals.
- 6) It is important to never overfill the fuel tank. Fill the tank only up to a maximum of 1/2" (13 mm) below the bottom of the filler neck to allow room for fuel expansion.
- 7) Replace gasoline cap and tighten securely.
- 8) Only utilize accessories and attachments that have been officially approved for use with this particular tractor by the manufacturer. Prior to usage, thoroughly read, comprehend, and adhere to all instructions provided with the approved accessory or attachment.

OPERATING

- 1) Statistical data reveals that individuals aged 65 years and above are involved in a significant proportion of riding tractor-related injuries. It is crucial for operators in this age group to assess

- their capacity to operate the riding tractor safely, ensuring the protection of both themselves and others from severe injuries.
- 2) Before attempting to start the tractor, ensure that the blades are disengaged and the parking brake is set.
 - 3) It is crucial to avoid placing hands or feet in close proximity to rotating parts or underneath the cutting deck. Coming into contact with the blade(s) can result in the amputation of hands and feet.
 - 4) Remain vigilant for the presence of holes, ruts, bumps, rocks, or any other concealed objects in the surroundings. The tractor can be overturned by uneven terrain, and tall grass has the potential to hide obstacles. Stay alert and cautious while navigating such areas.
 - 5) When mowing, strategically plan your pattern to prevent the discharge of materials towards roads, sidewalks, helpers, or similar areas. It is important to avoid directing the discharge of material against walls or obstructions, as this can cause the material to ricochet back towards the operator.
 - 6) Exercise caution and thoroughly assess the overhead clearances before driving under low-hanging tree branches, wires, door openings, and other potential obstructions. This careful inspection is necessary to avoid the risk of the operator being struck or pulled from the tractor, which could lead to severe injuries.
 - 7) Before performing any tasks such as removing the grass catcher, emptying grass, unclogging the chute, clearing any grass or debris, or making adjustments, ensure that you follow these steps:
 - (1) Disengage the blade(s).
 - (2) Set the parking brake.
 - (3) Stop the engine.
 - (4) Wait until the blade(s) come to a complete stop.Once these precautions have been taken and the blade(s) have come to a full stop, you can proceed with the necessary tasks
 - 8) Please note that your tractor is specifically designed for cutting normal residential grass that does not exceed a height of 10" (25 cm). It is essential to avoid attempting to mow through exceptionally tall, dry grass (such as in a pasture) or piles of dry leaves. Dry grass or leaves can come into contact with the engine exhaust and accumulate on the tractor deck, posing a significant fire hazard.
 - 9) Never carry passengers.
 - 10) Maintain a minimum distance of 10 feet (3 meters) from drop-offs, ditches, embankments, or the edges of water. It is crucial to avoid situations where a wheel of the tractor is positioned over the edge of a cliff, ditch, or any unstable edge, as this could result in the tractor suddenly overturning. Stay mindful of these hazards to ensure your safety.
 - 11) Blade contact or injuries caused by thrown objects can occur due to a missing or damaged chute deflector.
 - 12) It is essential not to operate the tractor without the chute deflector or the entire grass catcher in its proper position.
 - 13) Exercise extra caution when using grass catchers or other attachments as they can affect the stability of the tractor. Always follow the instructions provided by the attachment manufacturer.
 - 14) When crossing gravel drives, walks, or roads, and when not actively cutting grass, ensure the blades are stopped.
 - 15) Be mindful of traffic when operating near or crossing roadways. Remember, this tractor is not intended for use on public roadways.
 - 16) Only mow during daylight hours or in well-lit conditions.
 - 17) Do not operate the tractor while under the influence of alcohol or drugs.
 - 18) Prioritize slowing down before making turns and maintain smooth operation of the tractor. Avoid erratic operation and excessive speeds.
 - 19) The muffler and engine can become extremely hot and cause severe burn injuries. Do not touch them. Allow the tractor to cool for at least five minutes before performing any maintenance.

- 20) Never run the engine indoors or in poorly ventilated areas, as the engine exhaust contains carbon monoxide, an odorless and potentially lethal gas.

CHILDREN

- 1) Tragic accidents can occur if the operator is not vigilant about the presence of children. Children are often attracted to the tractor and the mowing activity, and they may not comprehend the associated dangers. Never assume that children will remain in the same location where you last saw them.
- 2) Ensure that bystanders, children, and pets are kept indoors and under the supervision of a responsible adult other than the operator during tractor operation. Stop the tractor immediately if anyone enters the operating area.
- 3) Never carry children, even when the blades are turned off. They may fall off and sustain serious injuries or interfere with safe tractor operation. Children who have been given rides in the past may unexpectedly appear in the mowing area seeking another ride and could be run over or backed over by the tractor.
- 4) Stay vigilant and turn off the tractor if a child or bystander enters the operating area.
- 5) Always check behind and down for small children to avoid back-over accidents.
- 6) Exercise extreme caution when approaching blind corners, doorways, shrubs, trees, or any objects that may obstruct your vision of a child who might run into the path of the tractor.
- 7) Children under the age of 14 should never operate this tractor. Those aged 14 and above should read and understand the instructions and safe operation practices outlined in this manual and on the tractor. They should receive proper training and supervision from an adult.
- 8) Prohibit children from joy riding on the tractor. The tractor is not a toy or a go-cart. Inform your children that the tractor can be dangerous, and they must keep their distance from it at all times.
- 9) Keep children away from hot or running engines as they can suffer burns from a hot muffler.
- 10) Remove the key when the tractor is unattended to prevent unauthorized operation. Ensure that the key is out of reach of small children.

SLOPE OPERATION

- 1) Slopes pose a significant risk of loss of control and tip-over accidents, which can result in severe injury or even death. Exercise extra caution on all slopes. If you are unable to safely back up the slope or feel uneasy about it, do not attempt to mow it.
- 2) Prioritize your safety by measuring any slope before operating the tractor on it. Use a slope measuring device, in addition to the slope gauge provided in this manual, to assess slopes before using the tractor on sloped or hilly areas. Smartphone applications can also be used for slope measurement. If the slope exceeds 15° (25%) as indicated on the slope gauge or measuring device, do not operate the tractor on that area as it could lead to serious injury.
- 3) Avoid mowing on slopes greater than 15° (25%).
- 4) Only mow up and down slopes that are less than 15° (25%) in angle; avoid mowing across slopes. Maintain low speeds and avoid sudden turns when operating on slopes.
- 5) Refrain from mowing on wet grass, as reduced traction can result in sliding or loss of control.
- 6) Do not operate the tractor under conditions where traction, steering, or stability may be compromised. Even if the wheels are stopped, tires can still slide.
- 7) Exercise caution when starting, stopping, and making turns on slopes. Avoid abrupt changes in speed or direction. Make turns slowly and gradually.
- 8) Use extra care when operating the tractor with a grass catcher or other attachments, as they can impact the stability of the tractor. Avoid using a grass catcher on slopes greater than 10° (17%).
- 9) Do not attempt to stabilize the tractor by placing your foot on the ground.
- 10) Maintain slow and gradual movement on slopes. Avoid sudden changes in speed or direction, as rapid acceleration can cause the front of the tractor to lift and result in rapid rollover backwards, leading to severe injury or death.

FIRE & FUEL

- 1) Exercise extreme caution when handling gasoline to avoid personal injury or property damage. Gasoline is highly flammable, and its vapors are explosive. Spilling gasoline on yourself or

your clothing can lead to serious injury, as it can ignite. If gasoline is spilled, immediately wash your skin and change clothes.

- 2) Ensure all cigarettes, cigars, pipes, and other potential sources of ignition are extinguished.
- 3) Use only approved gasoline containers.
- 4) Never remove the gas cap or add fuel while the engine is hot or running. Allow the engine to cool for at least five minutes before refueling.
- 5) Never refuel the tractor indoors.
- 6) Avoid storing the tractor or fuel containers indoors where there is an open flame, spark, or pilot light, such as near water heaters, space heaters, furnaces, clothes dryers, or other gas appliances.
- 7) If gasoline is spilled, wipe it off the engine and equipment. Clean up any oil or fuel spillage and remove any fuel-soaked debris. Move the tractor to a different area and wait five minutes before starting the engine.
- 8) To reduce fire hazards, ensure the tractor is free of grass, leaves, or any debris build-up. Follow the cleaning instructions in the Service and Maintenance section.
- 9) The tractor is designed to cut normal residential grass up to a height of 10" (25 cm). Avoid attempting to mow unusually tall, dry grass (e.g., pasture) or piles of dry leaves. Dry grass or leaves may come into contact with the engine exhaust or accumulate on the tractor deck, presenting a potential fire hazard.
- 10) Never overfill the fuel tank. Fill the tank up to no more than 1/2" below the bottom of the filler neck to allow space for fuel expansion.
- 11) Always replace the gasoline cap and ensure it is securely tightened. Do not operate the tractor without the fuel cap in place.
- 12) Allow the tractor to cool for at least five minutes before refueling or storing.
- 13) Never fill containers inside a vehicle or on a truck or trailer bed with a plastic liner. Always place containers on the ground away from your vehicle before filling.
- 14) Whenever possible, remove gas-powered equipment from the truck or trailer and refuel it on the ground. If that is not feasible, refuel such equipment on a trailer using a portable container rather than a gasoline dispenser nozzle.
- 15) Keep the nozzle in contact with the rim of the fuel tank or container opening at all times during fueling. Avoid using a nozzle lock-open device.

HAULING

- 1) When loading or unloading the tractor for transport, use properly secured full-width ramps.
- 2) Exercise extra caution during the loading or unloading process into a trailer or truck. Avoid driving the tractor up or down ramps as it could tip over, resulting in serious personal injury. Instead, manually push the tractor on the ramps for safe loading or unloading.
- 3) Before loading, raise the deck to the highest position to ensure proper clearance.

TOWING WITH YOUR TRACTOR:

- a. Attach towed equipment only at the hitch point of the tractor.
- b. Ensure that no children or others are in or on the towed equipment.
- c. Avoid towing on slopes greater than 5° (9%). Towing on slopes can cause loss of traction, loss of control, and difficulties in stopping due to the weight of the towed equipment.
- d. Travel at a slow speed and maintain extra distance to ensure sufficient stopping distance.

SERVICE

- 1) Ensure the tractor is in good working order before use. Replace worn or damaged parts before operating.
- 2) Do not modify the engine in any way as it can lead to unsafe speeds. Tampering with the governor setting may cause the engine to operate uncontrollably. Never change the factory setting of the engine governor.
- 3) Exercise caution when servicing sharp tractor blades. Wrap the blade or wear gloves for protection.
- 4) Prior to cleaning, repairing, or inspecting, ensure that the blades and all moving parts have come to a complete stop. Turn off the engine, remove the key, disconnect the spark plug wire(s), and ground them against the engine to prevent unintended starting.

- 5) Verify that the blades come to a complete stop within 7 seconds after disengaging the blade control, as per the maintenance schedule. If the blades do not stop within the specified time, have the tractor professionally serviced.
- 6) Regularly check the safety interlock system's proper functioning as per the maintenance schedule. If it malfunctions, have the tractor serviced by an authorized dealer.
- 7) Do not tamper with the safety interlock system or other safety devices. Regularly check their operation.
- 8) Check the blade(s) and engine mounting bolt torque according to the maintenance schedule. Visually inspect the blade(s) for damage and replace them with original equipment manufacturer (O.E.M.) blades only.
- 9) Use service parts that meet the original equipment specifications to ensure proper performance and safety.
- 10) Keep all nuts, bolts, and screws tightened to maintain safe working condition. Refer to the maintenance schedule for service intervals.
- 11) After striking a foreign object, stop the engine, disconnect the spark plug wire(s), and ground them against the engine. Thoroughly inspect the tractor for damage and repair it before resuming operation.
- 12) Do not attempt to make adjustments or repairs to the tractor while the engine is running.
- 13) Regularly check grass catcher components and the chute deflector for wear or damage. Replace any damaged components with original equipment manufacturer (O.E.M.) parts.
- 14) Maintain or replace safety and instruction labels as necessary.
- 15) Adhere to proper disposal laws and regulations for gas, oil, and other materials to protect the environment.

Slope Gauge

Slopes are a major factor related to slip and fall accidents which can result in severe injury or death. The machine is heavy and can speed up when going downhill. Be prepared to maintain control of the machine. To avoid loss of control, operate across slopes, not up and down. When turning, turn uphill, not down. Do not operate machine on slopes in excess of 15 degrees.

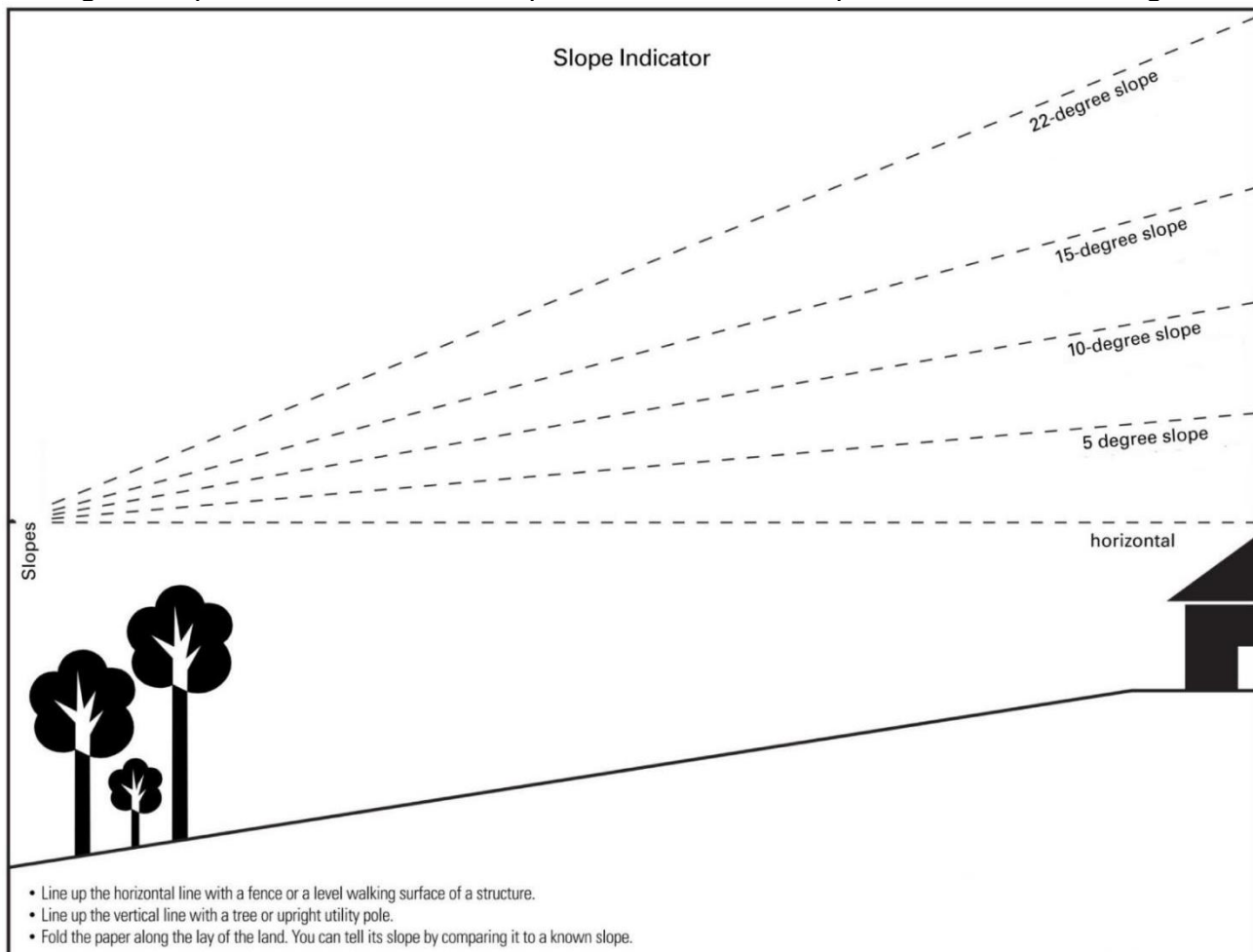

2. INTENDED USE

This equipment is intended for mowing lawns. Any use other than specifically permitted in this instruction may result in damage or injury. This equipment is intended for use by adults. Children or other people who are unfamiliar with the operating instructions must not operate this equipment.

2.1 TO THE USER

Welcome to your new Ride-On mower!















- To ensure safe and easy use of your machine, please read this entire manual carefully before operating it. This manual provides detailed instructions on how to properly set up, use, and maintain your Ride-On mower. It is crucial that you and any other individuals who will be operating the machine follow the recommended safety practices at all times to prevent personal injury or damage to property.
- Please note that this Operator's Manual may cover a range of product specifications for various models, and the characteristics and features discussed may not apply to all models. We reserve the right to make changes to product specifications, designs, and equipment without prior notice or obligation.
- Throughout this manual, all references to the right and left sides of the machine are observed from the operating position to ensure proper orientation.
- Please keep in mind that the engine manufacturer is responsible for all engine-related issues, such as performance, power-rating, specifications, warranty, and service. For more information, please refer to the engine manufacturer's Owner's/Operator's Manual, which is packed separately with your machine.

2.2 IMPORTANT NOTICE

- 1) Machines may not be fully assembled and may be sold in cartons. It is the user's responsibility to ensure that the assembly instructions in this manual are followed exactly.
- 2) Even if the machine is pre-assembled, the user must still check to ensure that it has been correctly assembled before every use.
- 3) Before starting the machine, the user must carefully inspect it to ensure that it is in good working condition. Do not operate the machine if it is damaged or not functioning properly.

2.3 SYMBOLS

	Read the instructions
	Wear protective gloves
	Wear safety glasses
	Wear hearing protection

	Do not expose to rain
	Keep bystanders away
	Caution – After the machine stops, the impact attachment continues to rotate. You must wait for it to come to a complete stop.
	Caution – hot surface keep safety distance.
	Unplug the spark plug before maintenance and repair. Read the instruction manual.
	Do not drive the tractor if the slope is more than 15 degree.
	Do not allow children to operate this machine
	Keep others away when you drive this machine!
	Danger! Do not bring a child when you drive this machine!
	Look down and behind before and while backing
	Keep hands/feet away from the running blade.
	Guarantee sound power level.
	The product complies with the applicable European directives and an evaluation method of conformity for these directives was done.
	Electrical products must not be disposed of with the domestic waste

3. YOUR PRODUCT

3.1 DESCRIPTION(FIG.1)

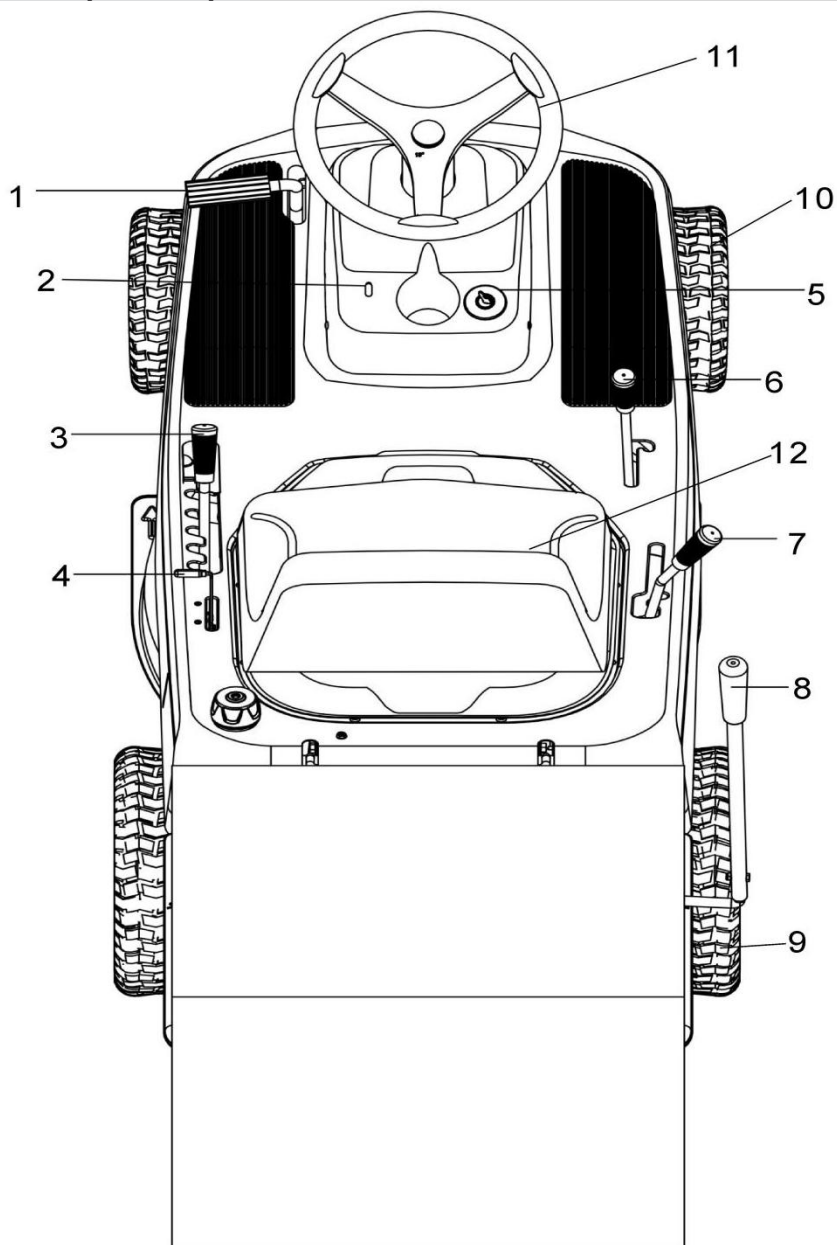

Fig.1

1.	Clutch /Brake Pedal	5.	Ignition key	9.	Rear Wheel
2.	Parking Brake Lever	6.	Blade Rotation Control	10.	Front wheel
3.	Lift Lever	7.	Shift Lever	11.	Steering Wheel
4.	Throttle Control	8.	Tipping Handle	12.	Seat

3.2 TECHNICAL DATA

Model	RAC6625PR	RAC6625SDPR
Engine	RV225-X	RV225-X
Displacement	224cm ³	224cm ³
Starting style	E-start	E-start
Engine power	4,5kW	4,5kW
Rated engine speed	2800/min	2800/min

Fuel tank capacity	4 L	4 L
Oil tank capacity	0.6 L	0.6 L
Cutting width	660mm	660mm
Number of forward gears	5	5
Forward speed	1.5-8 km/h	1.5-8 Km/h
Number of rear gears 1	1	1
Rear speed	1.8-2.7 km/h	1.8-2.7 km/h
Type of discharge	Rear, side and catcher	Side discharge
Mulching function	Yes	Yes
Volume of the grass catcher	120L	N/A
Net Weight	140kg	140kg
Cutting Height:	30-85mm (5 positions for height adjustment)	30-85mm (5 positions for height adjustment)
Wheel diameter	Front: 279mm /Rear 355mm	Front: 279mm /Rear 355mm
Sound pressure level	L _{pA} : 93,7dB(A) K=3.0 dB(A)	
Sound power level	L _{wA} : 95,5dB(A) K= 2,37 dB(A)	
Guaranteed Sound Power Level	98 dB(A)	
Vibration value	6,771m/s ² , K=1.5m/s ²	

4. ASSEMBLY

NOTE: This Operator's Manual covers 2 models. Not all features in this manual are applicable to all models and the model depicted may differ from yours. All references in this manual to the left or right side and front or back of the tractor are from the operating position only.

4.1 SEAT AND SEAT SAFETY SWITCH

Danger: For safety consideration, please plug in **Seat Safety Switch** before attempting to start the machine.

Note: **Seat Safety Switch** is designed to make sure that operator is on the seat when the machine is started. If

the operator does not sit on the seat then the engine can't be started or stop once the operator get off.

- 1) Carefully remove the plastic bag from the seat.
- 2) Raise **seat support** and secure in the **UP** position with the **seat support rod**.(Figure 2)
- 3) Align the holes in the **seat** to the holes in the **seat support**.The two **hex bolts** assembled the **seat** should go through **adjusting holes** and can slide on the slot.Fasten the **seat** to the **seat support** with fasteners as shown.(Figure 2)
- 4) Check the operating position of the seat.If the seat needs to be adjusted,loosen the two **wing bolts**.Slide the seat forward or backward along the seat **adjusting holes** as shown.Tighten the **wing bolts**.(Figure 2)
- 5) Plug in **Seat Safety Switch**.(Figure 2)

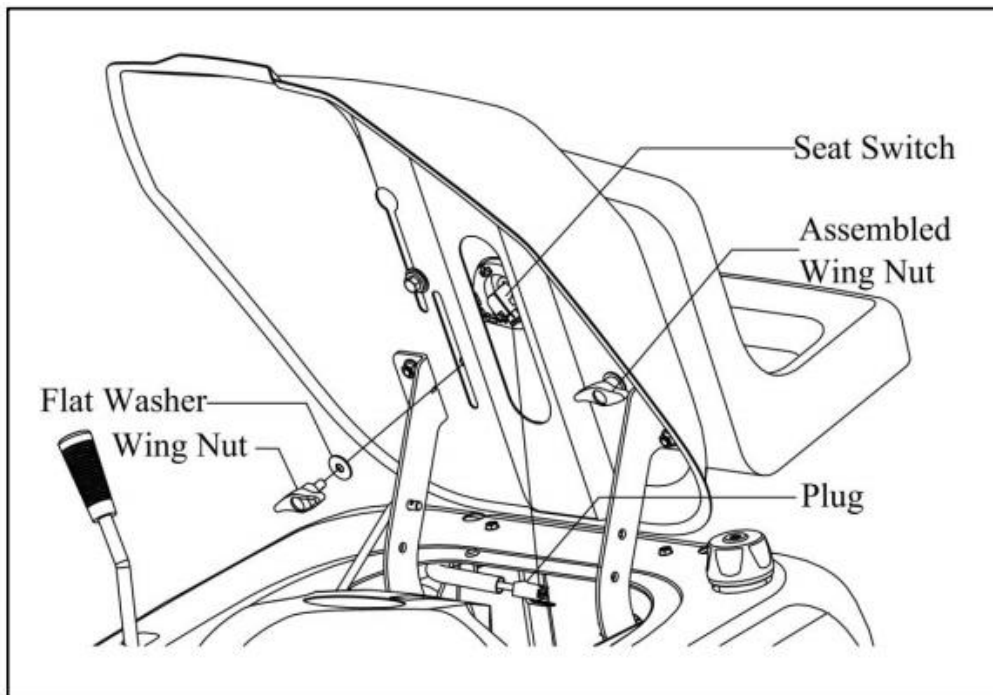

Figure 2

4.2 BATTERY

Warning: To prevent sparks, fasten the red cable to the positive(+) terminal before you connect black cable. Use the fasteners shown below to install the battery cables.

- 1) Remove the protective caps from the battery terminal.
- 2) Fasten the red cable to the positive(+) terminal with the fasteners as shown(Figure 3).
- 3) Fasten the black cable to the negative(-) terminal with the fasteners as shown(Figure 3).

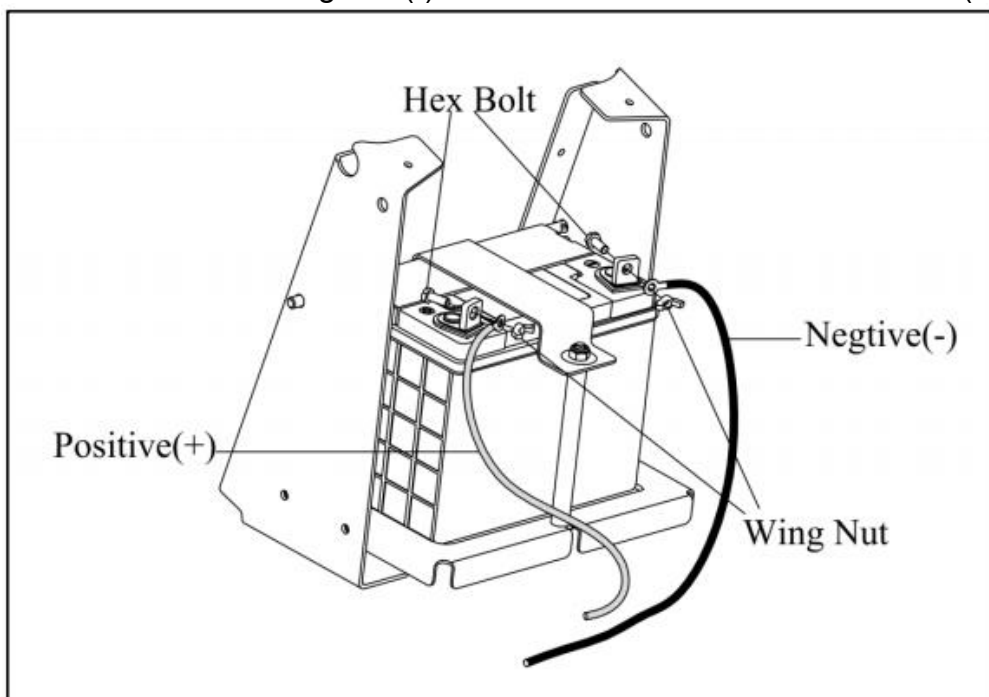

Figure 3

4.3 STEERING WHEEL

Remove any packing material which may be on the end of the steering wheel.

- 1) Make sure the front wheels point forward.
- 2) Slide the tube into the console. Make sure the end of the tube fits over the steering bushing.(Figure 4, Step-a)
- 3) Slide the steering wheel and steering post into the tube and console. Push on the steering wheel.

The steering post will lock onto the pinion gear. Pull on the steering wheel. Make sure that the steering post is locked in place. (Figure 4, Step-b)

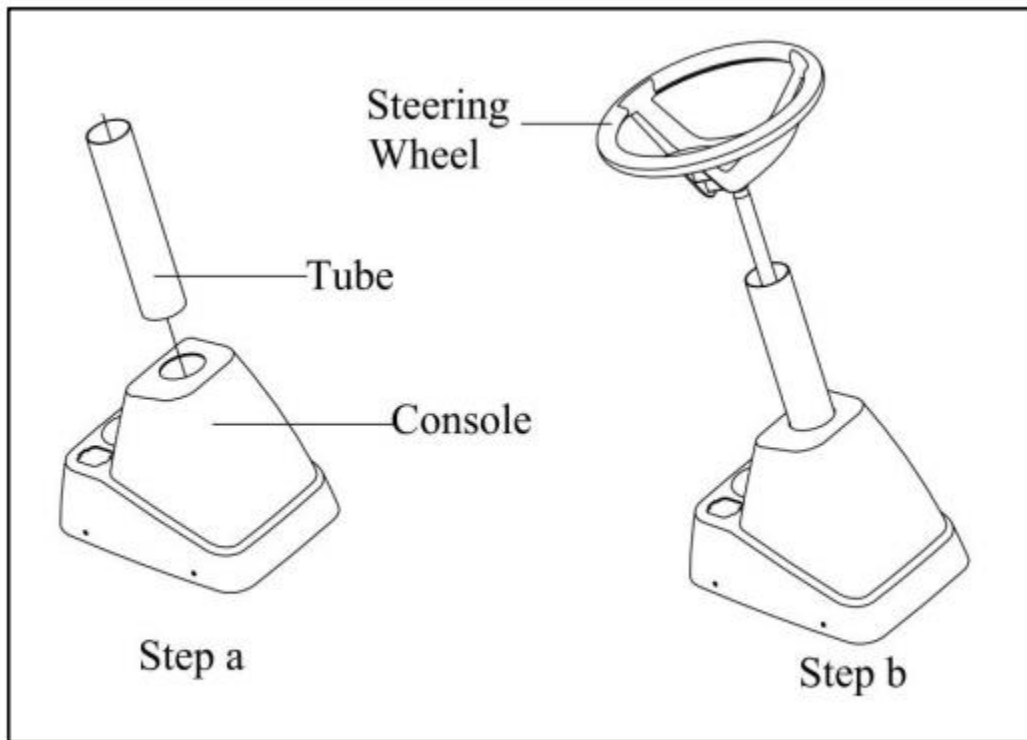

Figure 4

4.4 DISCHARGE PIPE AND GRASS CATCHER(OPTIONAL)

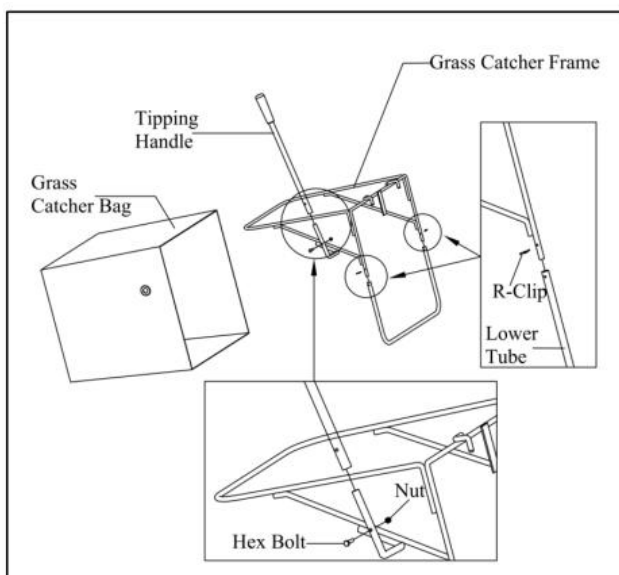

Figure 5

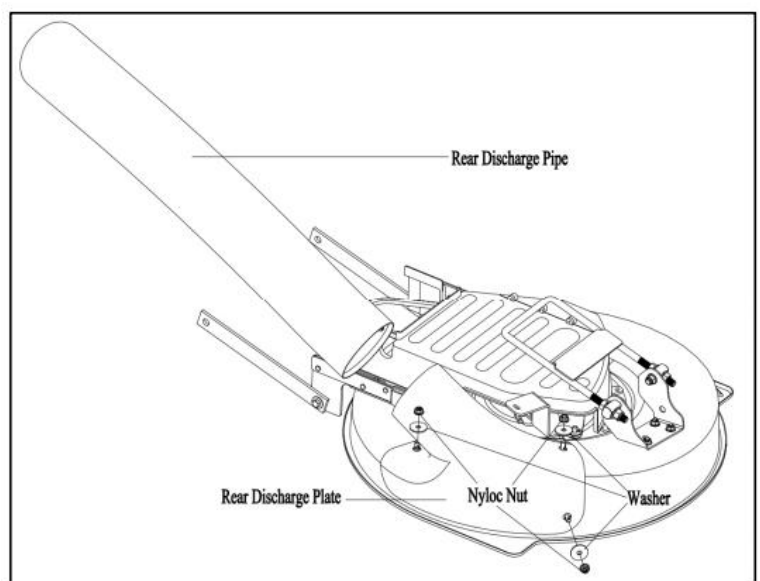

Figure 6

Warning: Hang up grass catcher in Rear Collection Mode, otherwise you may get injured by debris or rocks flying from grass pipe.

- 1) Assemble lower tube of grass catcher to the main frame of grass catcher. Use R-Clip to fix(Figure 5).
- 2) Mount grass catcher bag on to grass catcher frame
- 3) Assemble grass tipping handle with fasteners as shown(Figure 5).
- 4) Assemble rear discharge pipe and rear discharge cover together(Figure 6).
- 5) Mount rear discharge pipe assembly on to blade disc(Figure 6).
- 6) Hang up grass catcher. Use rubber hammer to make sure it's hooked in completely(Figure 7).
- 7) Plug in grass catcher switch

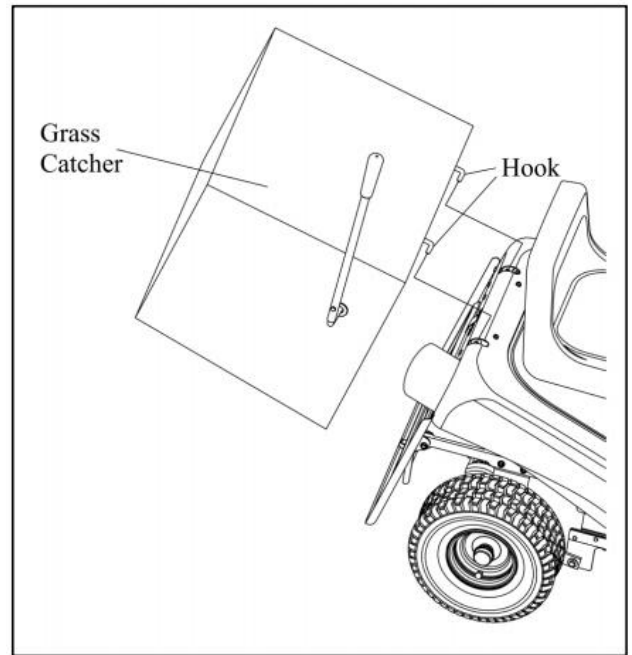

Figure 7

4.5 REAR WHEELS

Warning: For loading consideration, rear wheels may be installed in reverse direction and reassembly is required in this situation. It is users' responsibility to make sure the rear wheels are installed in operation direction.

Danger: If rear wheels are installed in transportation direction(reverse), the track width would be narrow and the tractor can be unstable.

Note: User can observe the position of valve stem to determine if rear wheels is assembled in operation mode. In operation mode, the valve stem is in outside. In transportation mode, the valve stem is in inside.

- 1) Observe the position of valve stem. If it's in transportation mode, go to next step.
- 2) Remove hub cap, e-ring, washer and rear wheel.
- 3) Reverse the direction of the wheel. Align the slot in the rear wheel with square key. Slide the rear wheel on axle.
- 4) Fasten the rear wheel with washer and e-ring(Figure 8).
- 5) Install hub cap. Make sure the washer holds the hub cap in place(Figure 8)

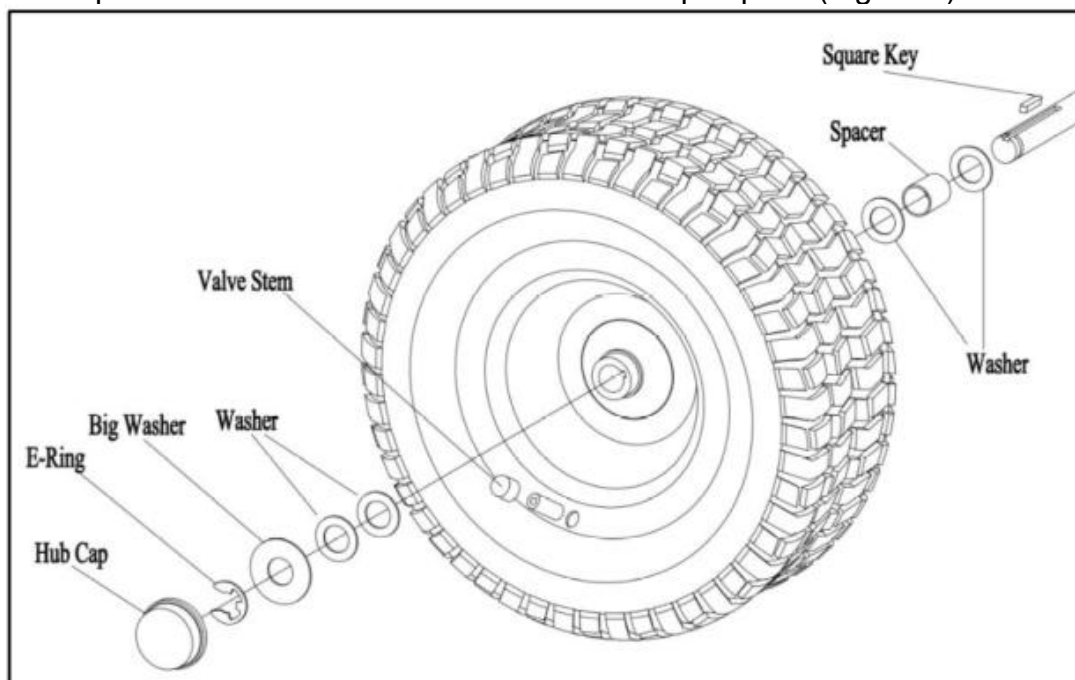

Figure 8

4.6 SIDE DISCHARGE CHUTE(OPTIONAL)

To discharge the grass out the side,install the side discharge chute as follows.

- 1) Remove the fasteners that secure the rear discharge pipe assembly or mulch plate.
- 2) Take out rear discharge pipe assembly or mulch plate.
- 3) Mount the side discharge chute on to the same bolts that secured the rear discharge pipe assembly(Figure 9) .
- 4) Secure the side discharge chute with fasteners.
- 5) Plug out grass catcher switch(If connected).

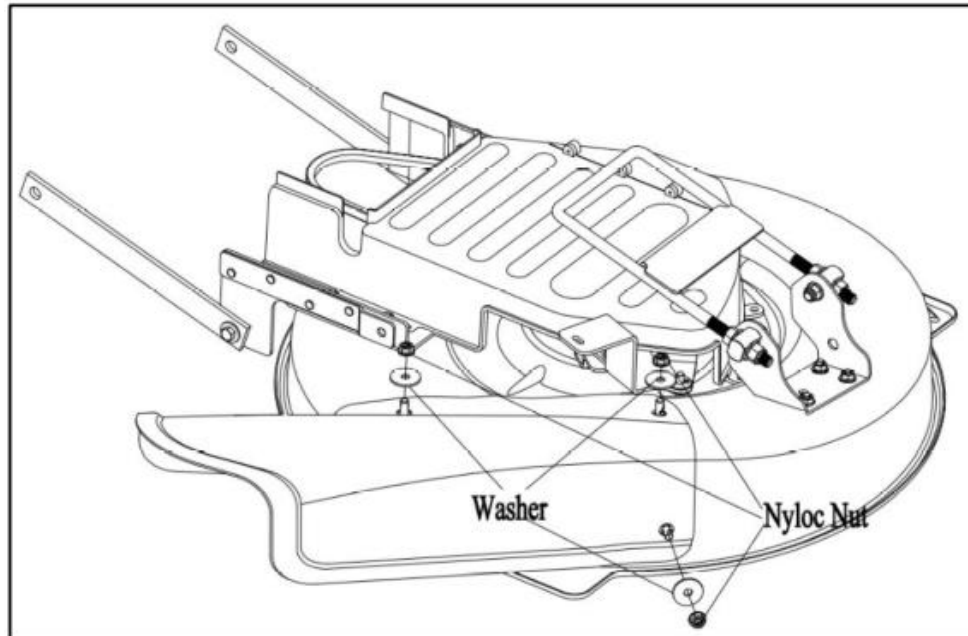

Figure 9

4.7 MULCH PLATE(OPTIONAL)

To mulch grass,install the mulch plate as follows.

- 1) Remove the fasteners that secure the rear discharge pipe assembly or side discharge chute.
- 2) Take out rear discharge pipe assembly or side discharge chute.
- 3) Mount the mulch plate(Figure 10).
- 4) Secure the mulch plate with fasteners.
- 5) Plug out grass catcher switch(If connected).

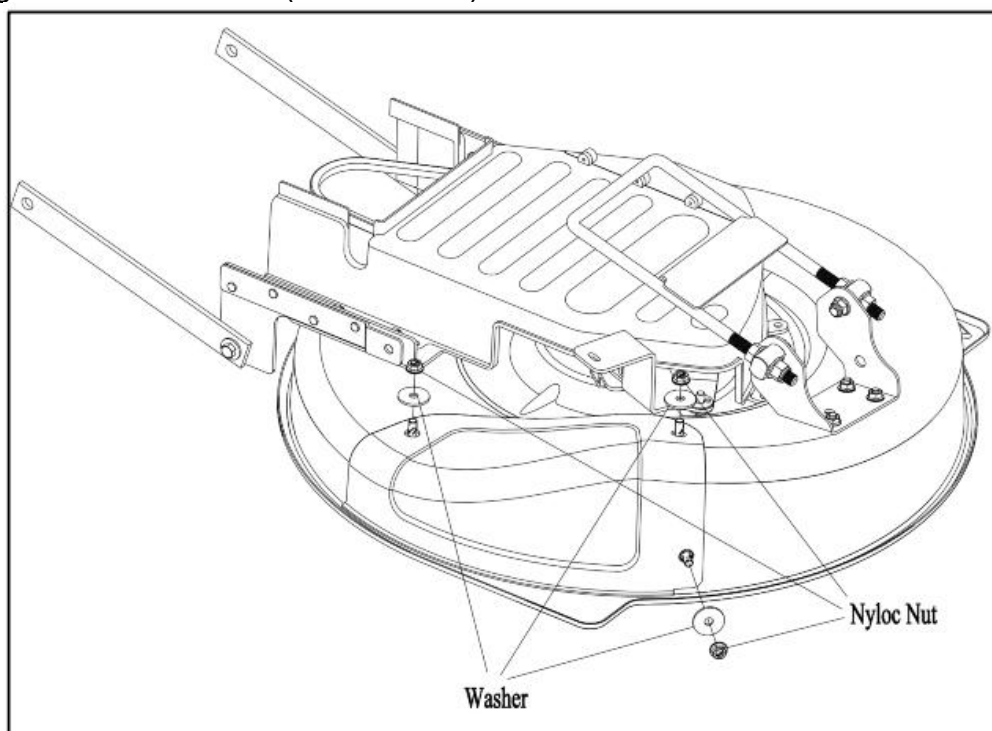

Figure 10

5. BEFORE USE

5.1 SET-UP

Note: Before you start mowing, do the following check first!

- 1) Check the engine oil.
- 2) Fill the fuel tank with gasoline.
- 3) Check the level of the mower housing.
- 4) Check the air pressure of the tires.
- 5) Make sure the battery cables are attached.

Warning: Before doing any assembly or maintenance to the mower, remove the wire from spark plug.

5.2 FILLING TANK

WARNING! Gasoline is extremely flammable.

Store fuel in specially designed cans for this purpose.

Fill the fuel tank only outdoors and before starting the engine. Do not smoke when filling the fuel tank or handling fuel.

Never open the fuel tank cap and never add fuel while the engine is running or when it is hot.

If fuel has spilled, do not start the engine any further, move the tool away from where the fuel has been spilled, and be careful not to create a spark or flame until the fuel vapours have dissipated.

Fully close all fuel tank and fuel canisters.

Before tilting the mower to maintain the blade or drain the oil, empty the fuel tank.

WARNING: Never fill the fuel tank indoors, while the engine is running, or before the engine has cooled down for at least 15 minutes after use.

CAUTION: Do not use unapproved gasoline, such as E15 and E85. Do not mix the oil with gasoline or modify the engine to operate with alternative fuels. The use of unapproved fuels will damage the engine parts and will void the engine warranty. To protect the fuel system from scale formation, add a fuel stabilizer to the fuel. All fuels are not identical. If start-up or performance problems occur, change supplier or fuel brand.

Fuel must meet the following criteria:

- Clean, new, and lead-free gasoline.
- A minimum octane rating of 87/87 AKI (91 RON). For use at high altitudes, see below
- A gasoline containing up to 10% ethanol is acceptable.
- Remove the fuel tank cap. Add fuel.
- Close the fuel tank with the cap.

Do not overfill. Wipe off any fuel that has overflowed before starting the engine.

5.3 ENGINE OIL

Recommended oil: We recommend the use of high-quality detergent oil classified for SF, SG, SH, SJ or higher. Do not use special additives.

Filling oil tank

- Open the oil tank.
- Directly fill the oil in the tank. Do not overfill.
- Close the oil tank. Wipe any spillage.

Checking the oil level

- Check the oil level when the engine is off and horizontal.
- Remove the plug / dipstick from the oil tank and wipe it off.
- Insert the oil tank plug / dipstick into the tank neck, without screwing it in, and then remove it to check the oil level.
- If the oil level is near or below the lower limit of the dipstick, remove the dipstick and fill the recommended oil reservoir up to the upper limit of the dipstick (bottom edge of the dipstick). Do

- not overfill.
- Replace the oil tank plug / dipstick.

5.4 CHECK THE LEVEL OF THE MOWER HOUSING

Make sure the level of cut is still correct. After you mow a short distance, look at the area that was cut. If it's incorrect, see the instruction on "How to Level the Mower Housing" in the Maintenance section of this instruction book.

5.5 CHECK THE TIRES

Check the air pressure in the tires. Tires with too much air pressure will cause the unit to ride rough. Also, the wrong air pressure will keep the mower housing from correct cutting level. The correct air pressure is 14 PSI (1 BAR). The tires were over inflated for shipment.

6. OPERATION

- **Blade Rotation Control:** Use the blade rotation control to start and stop the rotation of the blade.
- **Clutch/Brake Pedal:** The pedal has two function. The first function is a clutch. The second function is a brake.
- **Ignition Switch:** Use the ignition switch to start and stop the engine.
- **Shift Lever:** Use the shift lever to change the speed of the unit.
- **Lift Lever:** Use lift lever to change the height of cut.
- **Parking Brake Lever:** Use the parking brake lever to engage the brake when you leave the unit.
- **Throttle Control Lever:** Use the throttle control lever to increase or decrease the speed of the engine.

6.1 THROTTLE CONTROL/CHOKE CONTROL

Use the throttle/choke control to choke the engine for cold starts and increase or decrease the speed of the engine (Figure 11).

- 1) Move the throttle/choke control completely forward to the CHOKE position to start a cold engine.
- 2) The FAST position is marked with a rabbit. For normal operation and when using a grass catcher, move the throttle control to FAST position. For maximum charging of the battery and for a cooler running engine, operate the engine in the FAST position.
- 3) The engine governor is set at the factory for maximum performance. Do not adjust the governor to increase the speed of the engine.

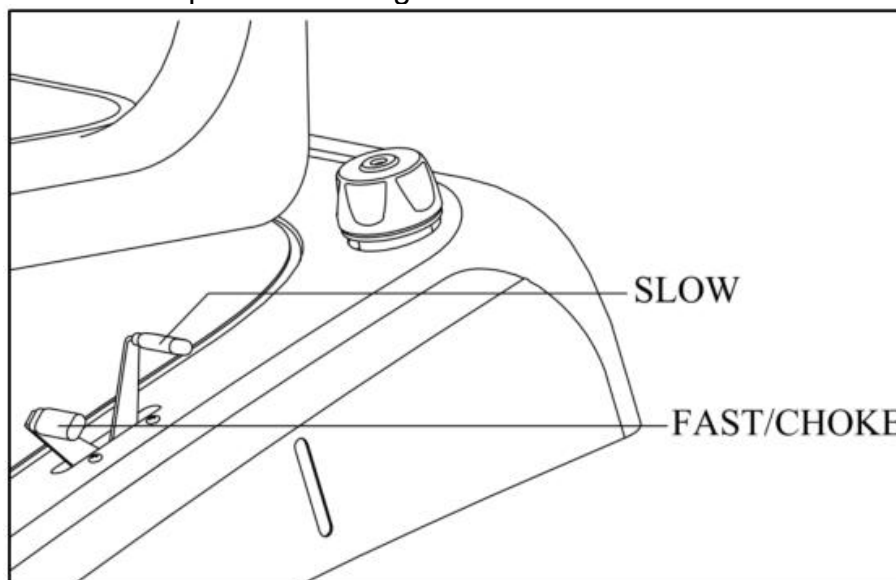

Figure 11

6.2 BLADE ROTATION CONTROL

Use the blade rotation control to engage the blade(Figure 12).

- 1) Before you start the engine,make sure the blade rotation control is in the DISENGAGE position.
- 2) To rotate the blade,move the blade rotation control forward to lock the blade in the ENGAGE position.
- 3) To stop the blade,move the blade rotation control to the DISENGAGE position.Before you leave the operator's position,make sure the blade has stopped rotating.
- 4) Before you ride the unit across a side a sidewalk or a road,move the blade rotation control to DISENGAGE position.

Warning: Always keep your hands and feet away from the blade,deflector opening,and the mower housing when the engine runs.

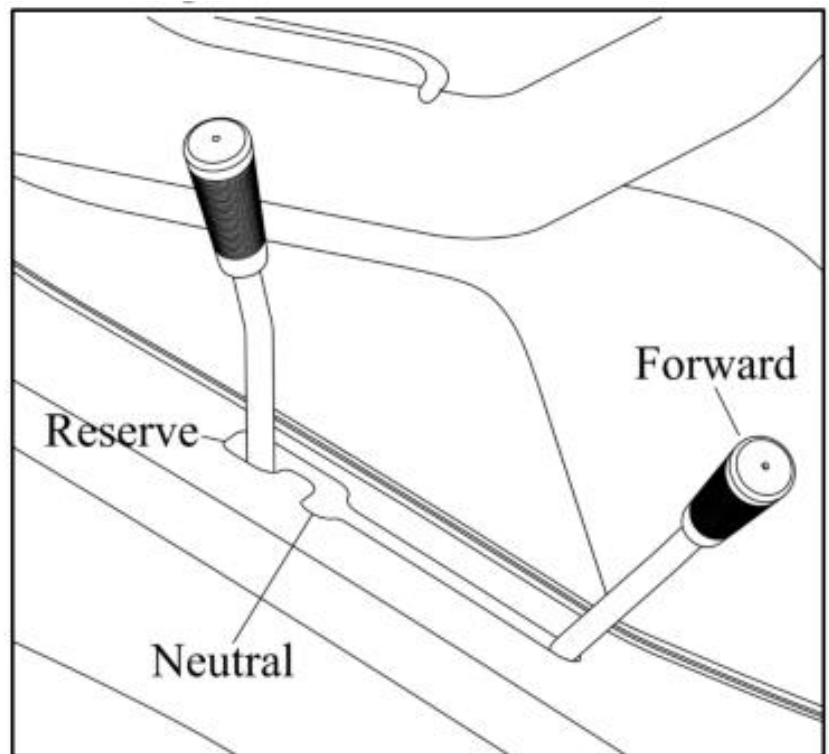
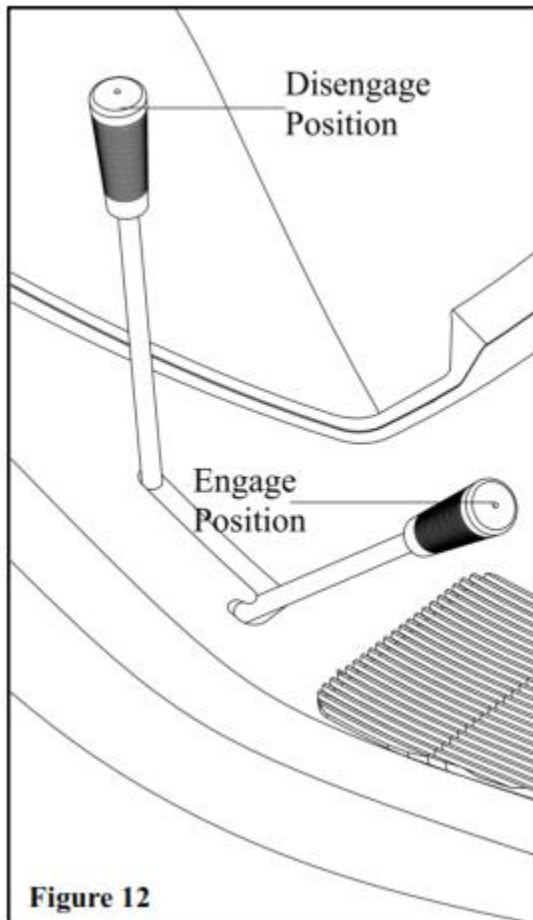

6.3 SHIFT LEVER

To change the forward speed or the direction of the unit, follow the steps below(Figure 13).

Warning: Before you move the shift lever,completely push the clutch/brake pedal forward to stop the unit.If the unit is not stopped,the gearbox can be damaged.

- 1) Completely push the clutch/brake pedal forward to stop the unit.Keep your foot on the pedal.
- 2) Move the throttle control lever to the SLOW position.
- 3) To go forward,move the shift lever to a forward speed setting.To go backward,move the shift lever to reverse.
- 4) Release the clutch/brake pedal.Do not keep your foot on the pedal.
- 5) Move the throttle control to the FAST position.

6.4 PARKING BRAKE LEVER

Warning: Always set parking lever when you get off the tractor(Figure 14).

- 1) Completely push the clutch/brake pedal forward.
- 2) Lift the parking brake lever.

- 3) Remove your foot from the clutch/brake pedal and then release the parking brake lever. Make sure the parking brake will hold the unit.
- 4) To release the parking brake, completely push the clutch/brake pedal forward. The parking brake will automatically release.

Warning: Before you leave the operator's position, move the shift lever to the neutral (N) position. Set the parking brake. Move the blade rotation control to the DISENGAGE position. Stop the engine and remove the ignition key.

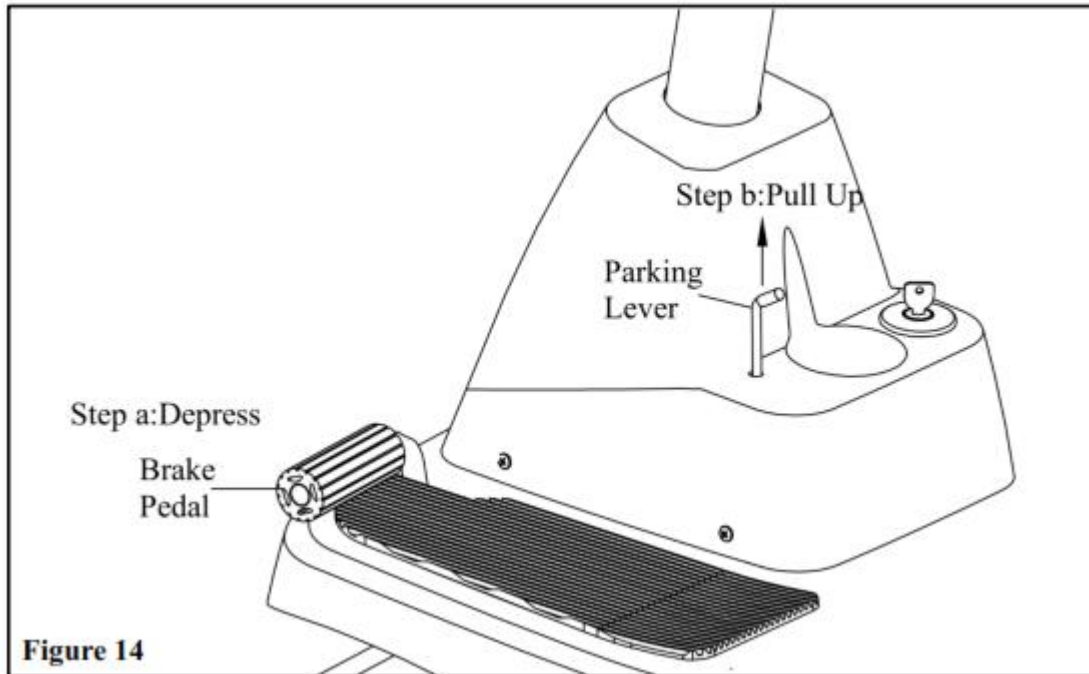

Figure 14

6.5 LIFT LEVER

To change the cutting height, raise or lower the lift lever as follows (Fig. 15).

- 1) Move the lift lever forward to lower the mower housing and back to raise the mower housing.
- 2) When you ride on a sidewalk or road, move the lift lever to the highest position and move the blade rotation control to the DISENGAGE position.

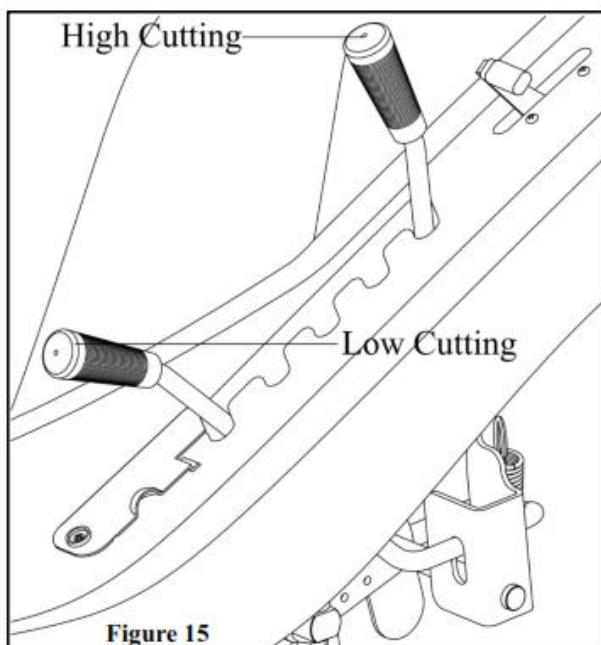

Figure 15

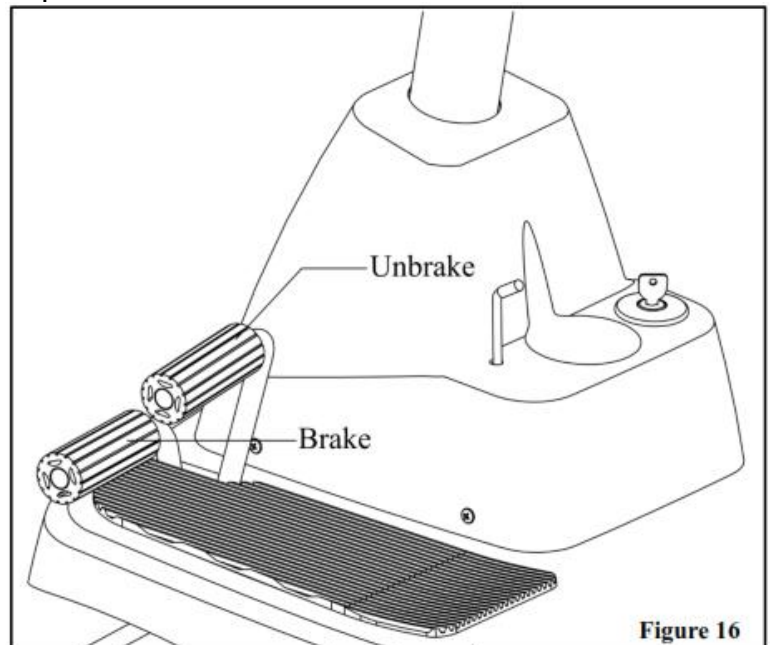

Figure 16

6.6 CLUTCH/BRAKE PEDAL

Clutch/Brake pedal is used to loose the driving belt and brake the transmission. There is an electrical switch under the pedal for safety purpose. If you want to start the engine, depress the pedal, otherwise the machine could not be ignited. (Fig. 16)

Note: If you find problems on braking, refer to Maintenance to fix the issue.

Warning: Do not depress the pedal in half way. The driving belt would be worn easily in semi-clutch situation.

6.7 STARTING THE MOWER

Warning: The electrical system has an operator presence system that includes a sensor switch for the seat. These components tell the electrical system if the operator is sitting on the seat. The system will stop the engine when the operator leaves the seat.

Note: Several conditions must be met for starting the engine. You must sit on the seat, disengage the blade and depress the brake pedal before attempting to start the engine. Please follow the steps:

- 1) Push the clutch/brake pedal completely forward. Keep your foot on the pedal.
- 2) Move the shift lever to the NEUTRAL(N) position.
- 3) Make sure the blade rotation control is in the DISENGAGE position.
- 4) If you are working on grass collecting mode, make sure the grass catcher is installed in the right place.
- 5) Move the throttle control completely forward to the CHOKE/FAST position.
- 6) Turn the ignition key to the start position. Release the key when the engine starts.
- 7) Slowly move the throttle control to the SLOW position.
- 8) Let a cold engine run for several minutes. Begin work when the engine is warm. To start a hot engine, move the throttle control to a position between FAST and SLOW.

6.8 STOPPING THE MOWER

- 1) Completely push the clutch/brake pedal forward to stop the unit. Keep your foot on the pedal.
- 2) Move the blade rotation control to the DISENGAGE position.
- 3) Move the shift lever to the NEUTRAL(N) position.
- 4) Set parking brake.

Warning: Make sure the parking brake will hold the unit.

- 5) Move the throttle control to the SLOW position.
- 6) To stop the engine, turn the ignition key to the OFF position. Remove the key.

Warning: Use seat support rod to maintain the seat support open for discharging the heat air (Figure 17).

Danger: Do not touch exhaust pipe in 1 hour after stopping the engine.

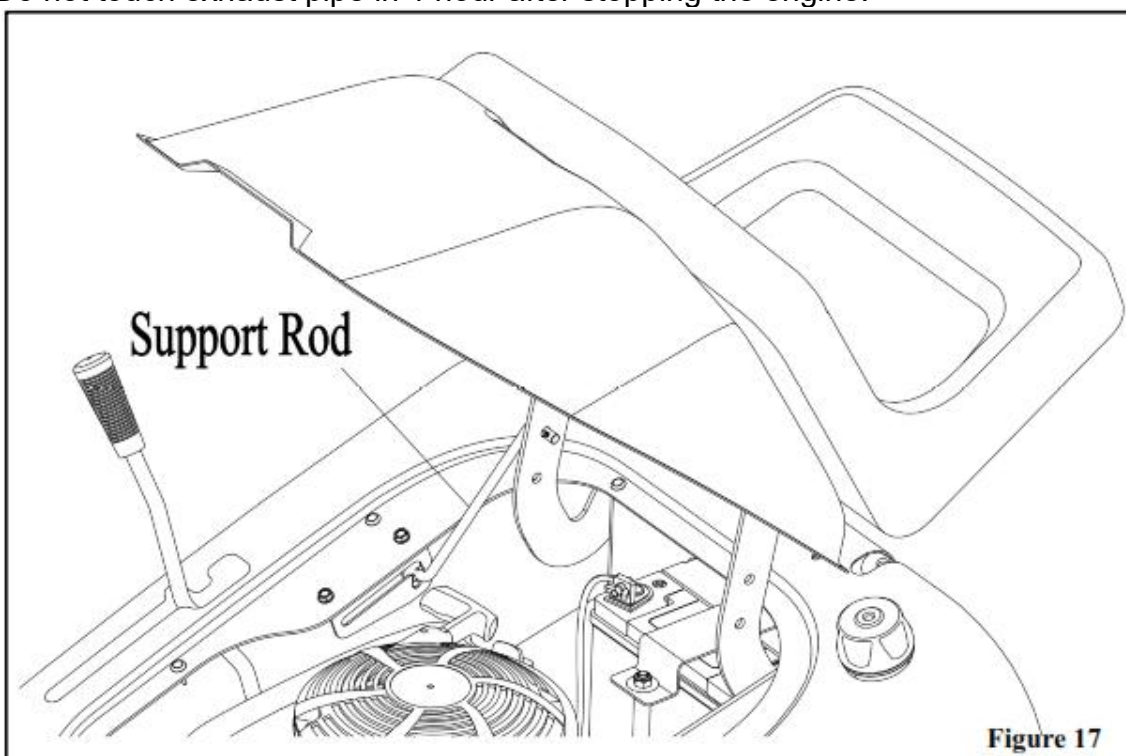

Figure 17

6.9 SIDE DISCHARGE FUNCTION

To mow and not collect your cuttings, the machine can be equipped with side discharge chute . Please refer to Assembly-Side Discharge Chute for installation.

Warning: Do not engage the blade when someone standing near discharge chute. Some debris may fly from the chute.

6.10 MULCH FUNCTION

Mulch Function allows you mulch the grass for a clean, fine cut. Please refer to Assembly-Mulch Plate for installation.

Mulching tips:

Mulching finely cuts the grass so that the grass can be easily recycled. Because the nutrients return to the soil, the lawn will need less fertilizer. To correctly mulch the lawn, follow the tips below.

- 1) The grass must be dry. If the grass is wet, it will be difficult to cut and cause heavy clumps of grass.
- 2) The grass must not be too tall. The maximum height to effectively cut is 4.5 inches. Set the height adjustment segment so that only the top third of grass is cut.
- 3) If the grass is more than 4.5 inches high, two mowings will be necessary. For the first mowing, set the height adjustment segment in the highest position. Then lower the cutting height for the second mowing.
- 4) Keep a sharp edge on the blade. A blade that is not sharp will cause the ends of the grass to become brown.
- 5) Clean the underside of the mower chassis. Grass and other debris can keep the mower from working correctly.

6.11 GRASS COLLECTION FUNCTION (FOR RAC6625PR)

The mower can be installed with a grass catcher. Please refer to Assembly-Discharge pipe and Grass Catcher for installation.

Note: For safety consideration, if the user dumps grass with tipping handle of grass catcher when blade is engaged, then the mower would stop.

Note: If the user wants to switch to other mode like mulch or side discharge, plug out the grass catcher switch, or the user can not start the mower.

6.12 USING YOUR MOWER

- 1) For a lawn to look better, check the cutting level of the mower housing. See Level the Mower Housing in the maintenance chapter.
- 2) For the mower housing to cut cut level, make sure the tires have the correct amount of air pressure.
- 3) Every time you use the unit, check the blade. Also, make sure the nut for the blade is tight.
- 4) Keep the blade sharpened. Worn blades will cause the ends of grass to turn brown.
- 5) Do not cut or bag grass that is wet. Wet grass will not discharge correctly. Let the grass dry before cutting.
- 6) If the grass is very high, cut two times to decrease the load on the engine. First cut with the mower housing in the highest position and then lower the mower housing for the second cut.
- 7) For better engine performance and an even discharge of the cut grass, always operate the engine with throttle in fast position.
- 8) When you use a grass catcher, operate the engine with throttle in fast position and the shift lever in first or second gear.
- 9) For better cutting performance and a quality cut, mow with the shift lever in one of the slower speeds.
- 10) After each use, clean the bottom and top of the mower housing for better performance. Also, a clean mower housing will help prevent a fire.

7. MAINTENANCE AND STORAGE

7.1 MAINTENANCE CHART

FREQUENCY	MAINTENANCE REQUIRED	COMMENT
Daily or before each	Maintenance engine	Refer to the Engine Owner's Manual
	Examine blade(s)	Check for cracks, wear, and excessive damage
	Remove debris from unit and mowing area	
	Examine all rotating and sliding parts	
	Check tire inflation	Refer to the Maintenance section
	Verify that the mower housing is level	Refer to the Maintenance section
	Examine V-belts	Check for cracks, wear, and excessive
	Check brake operation	Refer to the Operation and Maintenance sections
After completion of first 5 hours	Change oil	Refer to the Engine Owner's Manual
After 25 hours	Maintenance engine	Refer to the Engine Owner's Manual
	Remove, examine, sharpen, and balance blade(s).	Refer to Maintenance section
	Check adjustments: a. Blade Rotation Control b. Brake c. Clutch d. Steering	Refer to Maintenance section
	Lubricate chassis and mower housing	Refer to Where to Lubricate instructions
	Check the muffler: a. Torque b. For wear or burn out c. Condition of spark arrester, (if applicable)	
Before storage of 30 days or more	Prepare engine for storage	Refer to the Engine Owner's Manual
	Drain fuel system	Refer to warnings in the Owner's Manual
	Add fuel stabilizer	Refer to the Engine Owner's Manual
	Prepare battery for storage: a. Remove from unit. b. Fully charge. c. Move to cool dry place.	

7.2 GENERAL RECOMMENDATIONS

NOTE: Torque is measured in foot pounds (metric Nm). This measurement describes how tight a nut or bolt

must be. The torque is measured with a torque wrench.

- 1) The owner's responsibility is to maintain this product. This will extend the life of the product and is also necessary to maintain warranty coverage.

- 2) Check the spark plug, drive brake, lubricate the unit, and clean the air filter once a year.
- 3) Check the fasteners. Make sure all fasteners are tight.
- 4) Follow the **Maintenance** section to keep the unit in good operating condition.

WARNING: Before you make an inspection, adjustment, or repair to the unit, disconnect the wire to the spark plug. Remove the wire from the spark plug to prevent the engine from starting by accident.

7.3 CHECK THE MUFFLER

Check the muffler every 50 hours. Make sure the muffler is correctly mounted and is not loose. If the muffler is worn or burnt, replace with a new muffler. A worn muffler is a fire hazard and can also damage the engine.

If you mount a spark arrester to the muffler, also check the spark arrester when you check the muffler. If the spark arrester is worn or damaged, replace it with a new spark arrester. See your nearest authorized service center for a spark arrester.

7.4 INSPECT BLADE

If you keep the blade sharp and inspect the blade for damage, the blade will cut better and be more safe to operate. Frequently check the blade for excessive wear, cracks, or other damage. Frequently check the nut that holds the blade. Keep the nut tight. If the blade hits an object, stop the engine. Disconnect the wire to the spark plug. See if the blade is bent or damaged. Check the blade adapter for damage. Before you operate the unit, replace damaged parts with original equipment parts. See the authorized service center in your area.

WARNING: Before you inspect or remove the blade, disconnect the wire to the spark plug. If the blade hits an object, stop the engine. Check the unit for damage. The blade has sharp edges. When you hold the blade, use gloves or cloth material to protect your hands.

7.5 REMOVE AND INSTALL THE BLADE (FIG. 18)

WARNING: Always keep the nut tight that holds the blade. A loose nut or blade can cause an accident.

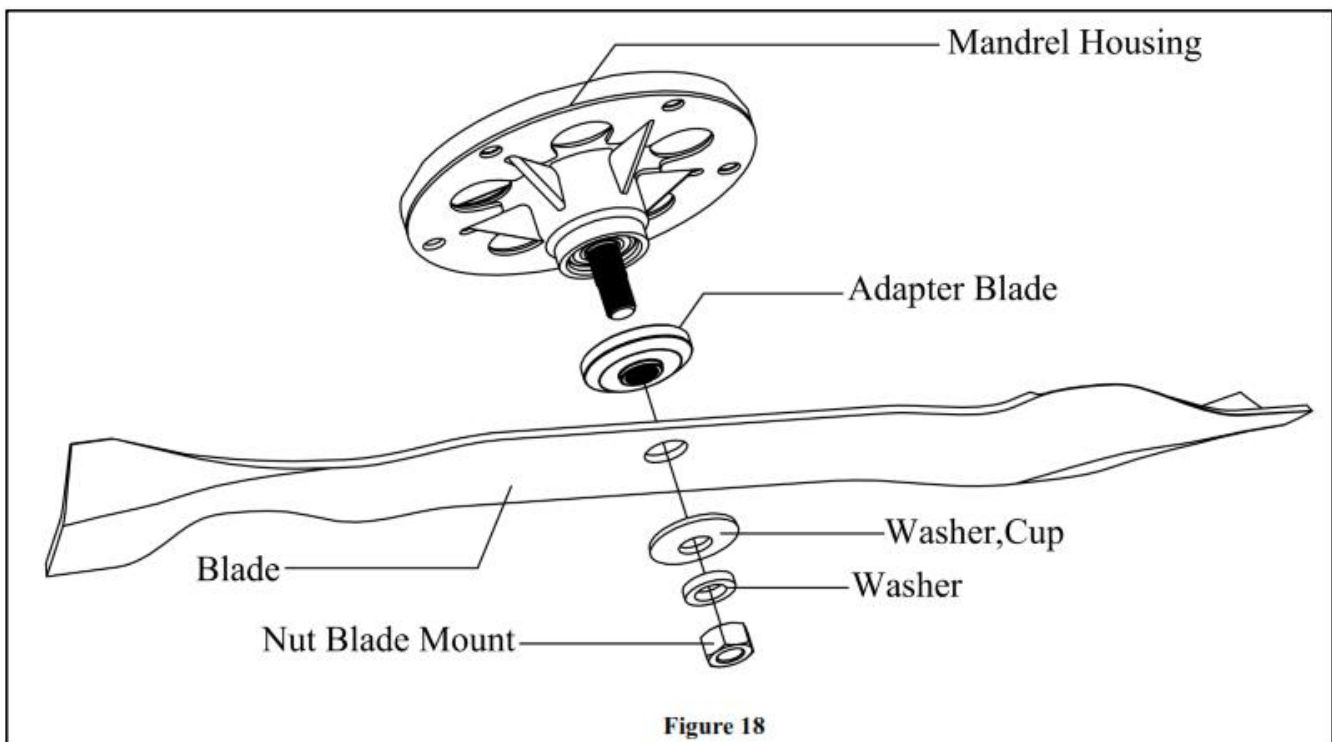

- 1) Remove the mower housing. See the instructions on "How To Remove The Mower Housing".
- 2) Use a piece of wood to keep the blade from rotating.
- 3) Remove the nut that holds the blade.

- 4) Check the blade and the blade adapter according to the instructions for "Inspect Blade". Replace a badly worn or damaged blade with an original equipment blade. See an authorized service center in your area
- 5) Clean the top and bottom of the mower housing. Remove all the grass and debris
- 6) Mount the blade and blade adapter on the mandrel.
- 7) Mount the blade so that the hi-lift edges are up. If the blade is upside down, the blade will not cut correctly and can cause an accident.
- 8) Fasten the blade with the original washers and nut. Make sure the outside rim of the Belleville washer is against the blade.
- 9) Tighten the nut that holds the blade to a torque of 35 foot pounds (47.5 Nm).
- 10) Install the mower housing. See "How To Install The Mower Housing".

7.6 HOW TO SHARPEN THE BLADE

WARNING: Vibration can be caused if the blade is not correctly balanced or if the blade is damaged. A blade that is damaged with cracks can break and cause an accident. Keep a sharp edge on the blade. A blade that is not sharp will cause the tips of the grass to become brown.

- 1) Sharpen the blade two times a year or every 25 hours.
- 2) Remove the blade according to the instructions in "How To Remove And Install The Blade"
- 3) Clean the blade with a brush, soap and water. Check the blade. Look for cracks, nicks, or other damage.

Replace a badly worn or damaged blade with an original equipment blade. See an authorized service center in your area.

- 4) Sharpen the blade with a file. Make sure you keep the original bevel angle
- 5) Make sure the blade is balanced. Use a screwdriver and hold the blade parallel to the ground. A blade that is balanced will stay parallel to the ground. If the blade is not balanced, the heavy end will rotate toward the ground. Sharpen the heavy end until the blade is balanced.
- 6) A new blade will cut better than a badly worn blade. Every three years, have an authorized service person inspect the blade or replace the old blade with an original equipment blade
- 7) Assemble the blade according to the instructions "How To Remove And Install The Blade".

7.7 CHECK THE BLADE ROTATION CONTROL

WARNING: To prevent an injury, the blade rotation control must operate correctly. In normal usage, the **blade rotation control** will not require an adjustment. However, if the cutting performance decreases or the quality of cut is poor, make the following changes.

- 1) When you mow, make sure the **throttle control** is in the **FAST** position.
- 2) Move the **blade rotation control** to the **DISENGAGE** position.
- 3) Stop the engine. Disconnect the wire from the spark plug.
- 4) Check the blade(s). Keep a sharp edge on the blade(s). A blade that is not sharp will cause the tips of the grass to become brown.
- 5) If the quality of cut has not improved, replace the mower drive belt. See "How To Replace The Mower Drive Belt". If replacing the belt does not correct the problem, take the unit to an authorized service center.
- 6) Move the blade rotation control to the **DISENGAGE** position. Stop the engine. Disconnect the wire from the spark plug.
- 7) Check the operation of the blade brake. Rotate the pulley with your hand. Make sure the **brake pad** is pressed tightly against the pulley (Fig. 19).

WARNING: If the **brake pad** does not press tightly against the pulley, take the unit to an authorized service center.

- 8) Move the blade rotation control to the **ENGAGE** position.
- 9) Check the pad for the blade brake. If the pad is excessively worn or damaged, replace the **brake pad** assemblies. Correct replacement parts and assistance are available from an authorized service center.
- 10) Attach the wire to the spark plug. Mow for a short distance and again check the operation of the **blade rotation control**.

- 11) When you move the blade rotation control to the **DISENGAGE** position, all movement will stop within seven seconds. If there is movement of the belt or the blades continue to rotate, engage and disengage the blade rotation control five times to remove any excess rubber from a new mower drive belt. If you need assistance, take the unit to an authorized service center.

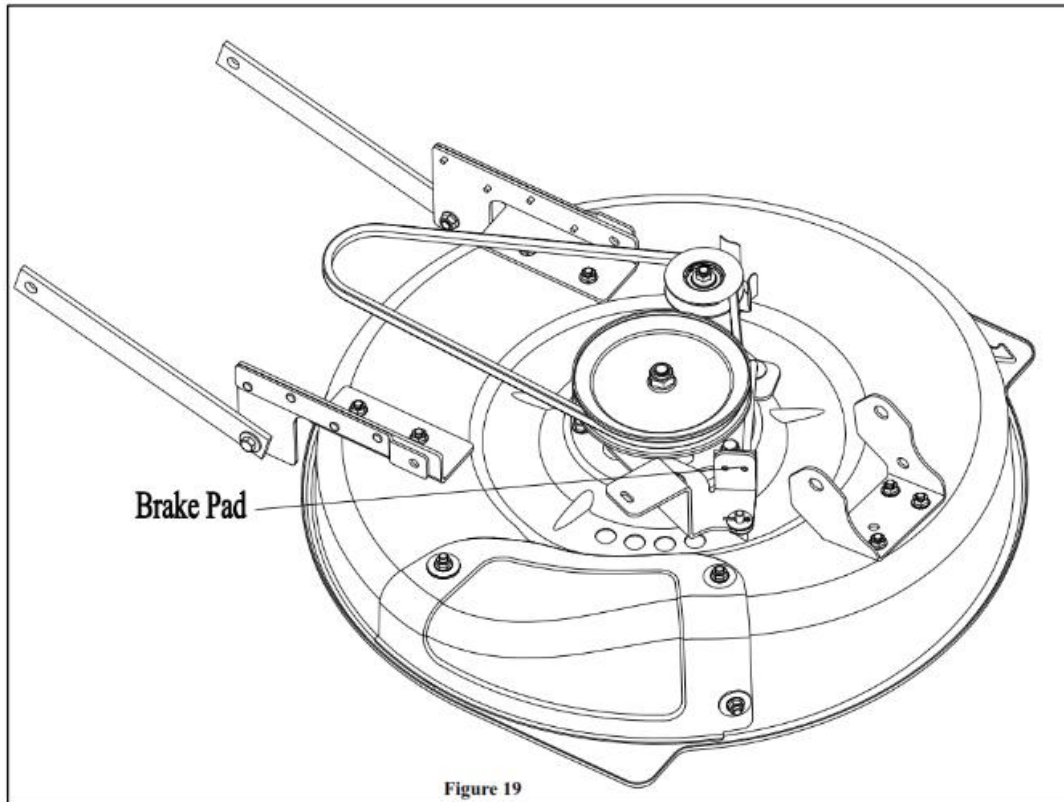

Figure 19

7.8 HOW TO CHECK AND ADJUST THE DRIVE BRAKE

Completely push the **clutch/brake pedal** forward. Set the **parking brake**. Move the **shift lever** to the **NEUTRAL (N)** position. Push the unit. If the rear wheels rotate, adjust the drive brake as follows (Figure 20).

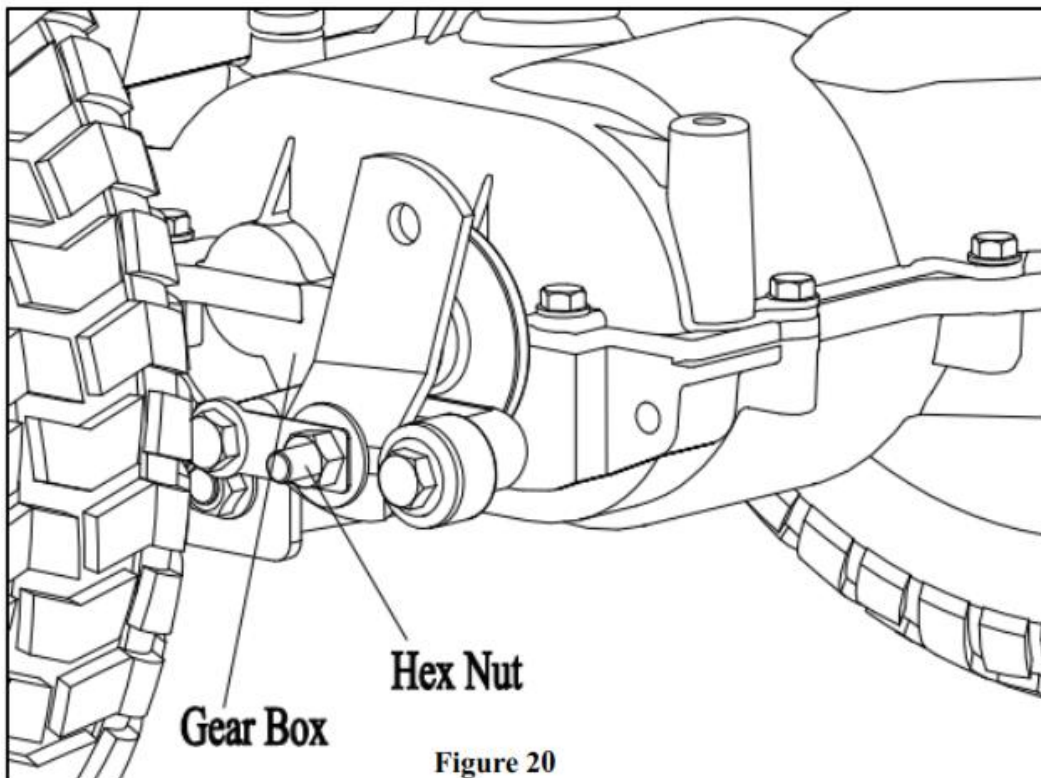

Figure 20

- 1) The location of the drive brake is on the left side of the gearbox.

- 2) Make sure the **parking brake** is set and the **shift lever** is in **NEUTRAL (N)**. Turn the hex nut in a clockwise direction until the rear wheels do not turn when the unit is pushed forward.
- 3) Release the parking brake and push the unit. If the unit does not roll, turn the hex nut in a counterclockwise direction until the unit rolls.
- 4) Set the **parking brake**. Push the unit. If the rear wheels do not turn, the drive brake is correctly adjusted. Release the parking brake.

WARNING: If you cannot correctly adjust the drive brake, replace the brake pads. Correct replacement parts and assistance are available from an authorized service center.

7.9 HOW TO CHECK AND ADJUST THE CLUTCH

If the motion drive belt is loose, the clutch will slip when;(1) going up a hill,(2) pulling a heavy load, or (3) the unit will not move forward.Adjust the clutch as follows(Figure 21).

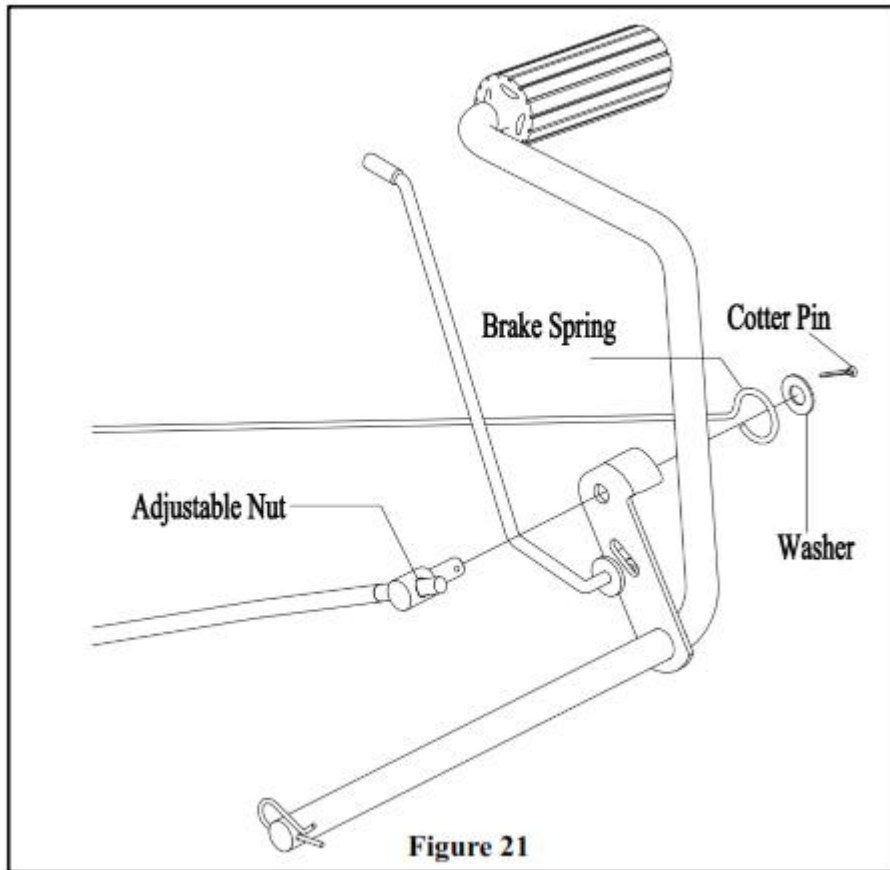

WARNING: Before you make an inspection, adjustment, or repair to the unit, disconnect the wire to the spark plug. Remove the wire from the spark plug to prevent the engine from starting by accident.

- 1) Check the routing of the motion drive belt. Make sure the belt is installed correctly and is inside all the belt guides.
- 2) Remove the cotter pin, washer, and brake spring from the adjustable nut.
- 3) Disconnect the adjustable nut from the brake lever assembly.
- 4) Align the hole in the **brake lever** with the rear of the slot in the frame.
- 5) Push the clutch rod toward the rear. Turn the adjustable nut until the nut will fit through the hole in the brake lever.
- 6) Assemble the adjustable nut to the brake lever and to the brake spring. Fasten with the washer and cotter pin.
- 7) If the belt still slips after the clutch has been adjusted, then the motion drive belt is worn or damaged and must be replaced. See "**How To Replace The Motion Drive Belt**"

7.10 HOW TO ADJUST THE SHIFT LEVER

If the **NEUTRAL(N)** position on the shift lever does not match neutral on the gearbox, adjust the shift lever

as follows(Figure 22).

- 1) Stop the engine.
- 2) Disconnect the adjuster nut from the shifter yoke.
- 3) Make sure the shift lever is in the **NEUTRAL(N)** position.
- 4) Push the unit forward. Make sure the gearbox is in **NEUTRAL(N)**.
- 5) To align the adjuster nut with the hole in the shifter yoke, tum the adjuster nut.
- 6) Connect the adjuster nut to the shifter yoke.
- 7) Make sure the **NEUTRAL(N)** position on the **shift lever** matches neutral on the gearbox.

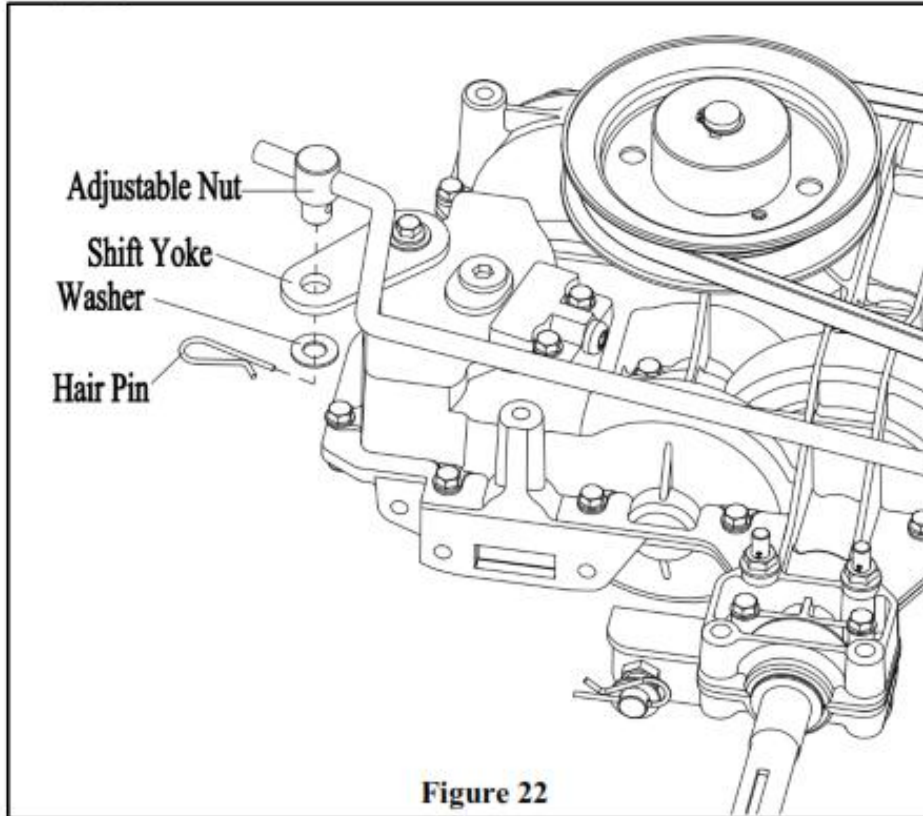

Figure 22

7.11 MAINTENANCE FREE BATTERY

How To Remove The Battery

To charge or clean the battery, remove the battery from the unit as follows.

WARNING: To prevent sparks, disconnect the black battery cable from the **negative (-)** terminal before you disconnect the red cable.

WARNING: The battery contains sulfuric acid which is harmful to the skin, eyes and clothing. If the acid gets on the body or clothing, wash with water.

- 1) Disconnect the black cable from the **negative (-)** terminal.
- 2) Disconnect the red cable from the **positive (+)** terminal.
- 3) To disconnect the battery retainer from the battery tray, push in on the lower end of the battery retainer.
- 4) Remove the battery from the right side of the unit.

7.12 HOW TO CLEAN THE BATTERY

- 1) Remove the battery.
- 2) Wash the battery with a solution of one gallon of water and four tablespoons of baking soda (sodium bicarbonate). Make sure the solution does not get into the battery cells.
- 3) Clean the terminals and the ends of the cables with a wire brush.
- 4) Install the battery.
- 5) To prevent corrosion, apply grease to the battery terminals.

7.13 HOW TO CHARGE THE BATTERY

If the unit is not running for a long time, the battery power could run out, and the engine can't be ignited electrically. Follow the instruction to charge:

- 1) Plug out **seat safety switch**.
- 2) Plug out **grass catcher switch**.
- 3) Use **support rod** to support the **seat support**.
- 4) Brake the unit with **parking lever**.
- 5) Disengage the **blade rotation control**.
- 6) Pull the engine to start.
- 7) Running the unit for 10 minutes to charge the battery.

Warning: Step 1 to Step 5 must be done, otherwise the circuit could not turn on.

7.14 LUBRICATION

Apply grease with a brush to the areas shown. Lubricate the areas shown with engine oil (Figure 23).

NOTE: Apply grease to the steering gear assembly.

CAUTION: If the unit is operated in dry areas that have sand, use a dry graphite spray to lubricate the unit.

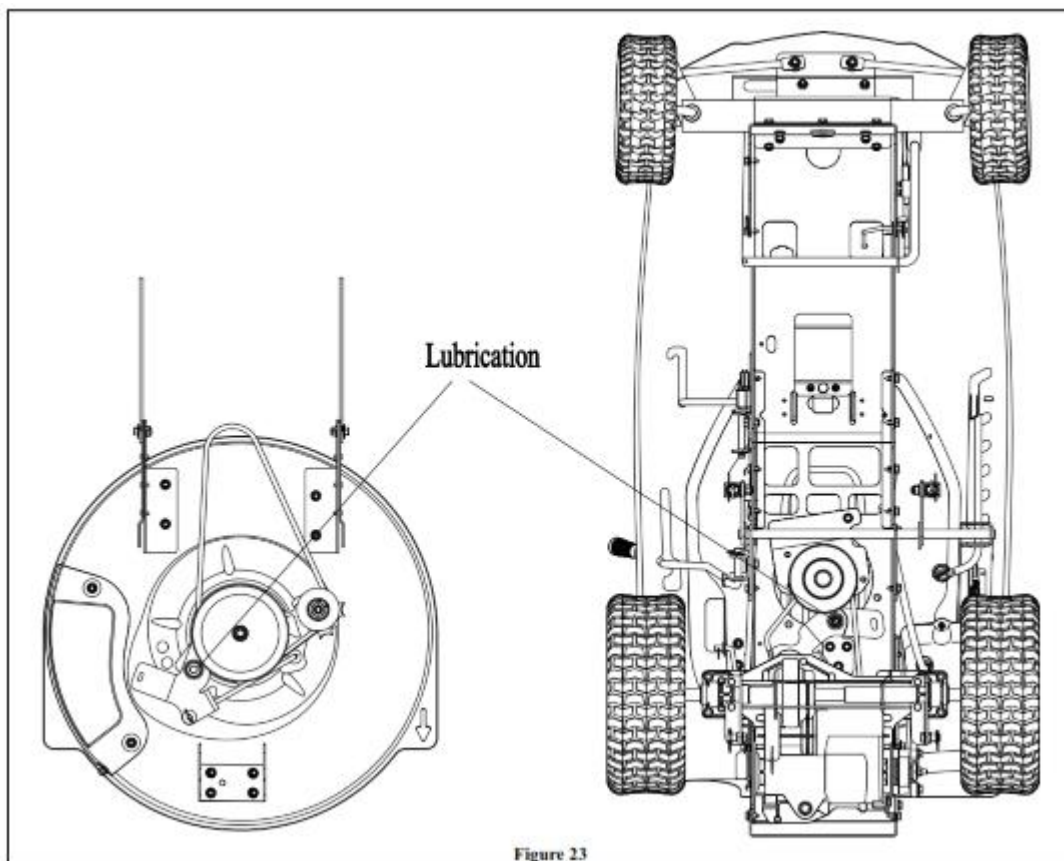

7.15 HOW TO CHECK THE FUEL FILTER

NOTE: Before you replace the fuel filter or the fuel line, the fuel tank must be empty.

If the fuel filter is dirty, the engine will run rough and have less performance. Remove the old filter. Replace the old filter with a new filter. Use an original equipment part. See an authorized service dealer in your area.

7.16 CHECK THE TIRES

Check the air pressure in the tires. Tires with too much air pressure will cause the unit to ride rough. Also, the wrong air pressure will keep the mower housing from cutting level. The correct air pressure is 14 PSI (1 BAR).

7.17 HOW TO LEVEL THE MOWER HOUSING

If the mower housing is level, the blade will cut easier and the lawn will look better.

WARNING: Before you make an inspection, adjustment, or repair to the unit, disconnect the wire to the spark plug. Remove the spark plug wire to prevent the engine from starting by accident.

- 1) Make sure the unit is on a hard flat surface.
- 2) Check the air pressure in the tires. If the air pressure is incorrect, the mower housing will not cut level. Make sure the tires are inflated to 14 PSI.(1 BAR).
- 3) Open the cover.
- 4) Move the **lift lever** to the **LOWEST** position.
- 5) Loosen the front and rear **adjustable nut** (Figure 24).Make sure both sides of the mower housing are setting on a flat surface.Be noticed that the front height of blade disc to support surface should be 22cm
- 6) Tighten the front and rear **adjustable nut**. Make sure the **adjustable nut** are tight. If necessary use a wrench to tighten the **adjustable nut**.
- 7) Close the cover.
- 8) Mow for a short distance.If the height of cut is not level, repeat the above steps.

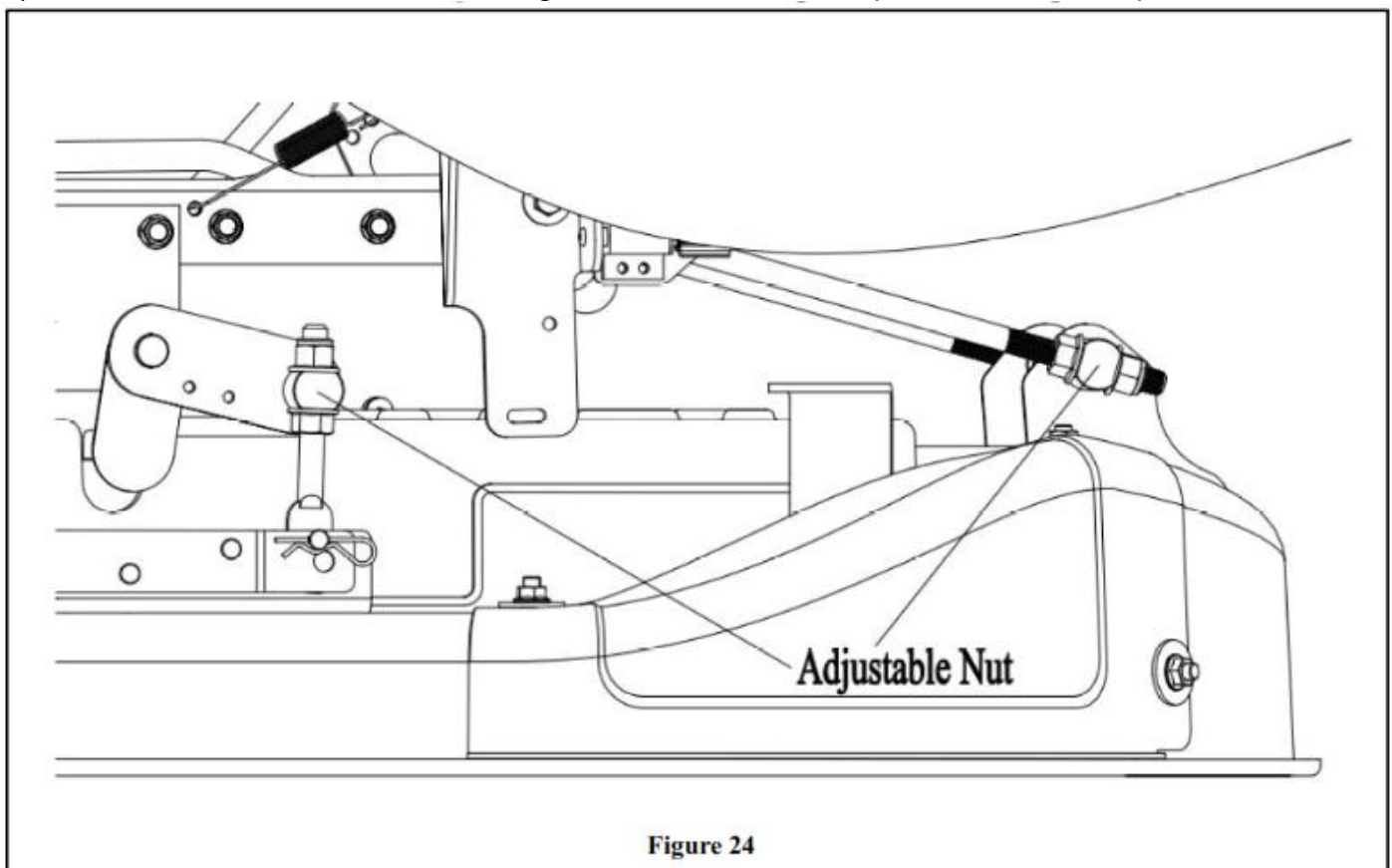

Figure 24

7.18 HOW TO REMOVE THE MOWER HOUSING

NOTE:Refer to explosion illusion in last part of the manual.

- 1) Move the blade rotation control to the **DISENGAGE** position.
- 2) Remove the hair pins and the washers from the rear suspension arms.
- 3) Remove the hair pins and washers from the suspension links.
- 4) Disconnect the extension spring from the blade control rod.
- 5) Disconnect the front hanger from the frame support.
- 6) Remove the mower drive belt from the stack pulley.
- 7) Pull the mower housing away from the right side of the unit.
- 8) To operate without the mower housing, move the **lift lever** to the TOP position.

7.19 HOW TO INSTALL THE MOWER HOUSING

- 1) Push the mower housing under the right side of the unit.

- 2) Put the mower drive belt around the stack pulley. Make sure the "V" side of the mower drive belt is against the stack pulley. Also, make sure the mower drive belt is not twisted.
- 3) Attach the front hanger to the frame support with the hanger rod. Fasten with the fasteners as shown.
- 4) Make sure the mower drive belt is between the stack pulley and the two belt guides.
- 5) Attach the suspension links to the lifter assembly. Fasten with the washers and hair pins.
- 6) Attach the rear suspension arms to the suspension brackets. Fasten with the washers and hair pins.
- 7) Attach the extension spring to the blade control rod.
- 8) Move the blade rotation control to the **ENGAGE** position. Make sure the mower drive belt is inside all the belt guides and is also below the spacer tube.
- 9) Make sure the mower housing is level. See the instructions on "How To Level The Mower Housing".
- 10) Check the operation of the blade rotation control. See the instructions on "How To Adjust The Blade Rotation Control".

7.20 HOW TO REPLACE THE MOTION DRIVE BELT

Removal

- 1) Remove the mower housing. See the instructions on "How To Remove The Mower Housing".
- 2) Completely push the pedal forward and engage the **parking brake**.
- 3) Remove the idler pulley (**Refer to explosion illusion in last part of the manual**).
- 4) Loosen the belt guides next to the drive pulley.
- 5) Remove the motion drive belt from the drive pulley.
- 6) Remove the motion drive belt from the stack pulley. A correct replacement part or assistance is available from an Authorized Service Center in your area.

Installation

- 1) 1. Slide the motion drive belt between the stack pulley and the belt guides. Install the motion drive belt on the top pulley of the stack pulley. Make sure the "V" side of the belt is against the pulley.
- 2) Install the end of the motion drive belt around the drive pulley.
- 3) Make sure the motion drive belt is inside of the belt guides next to the drive pulley. Tighten the belt guides.
- 4) Put the belt around the idler pulley. Assemble the idler pulley. Fasten the idler pulley with the hex nut. Make sure the "V" side of the belt is against the idler pulley. Also, make sure the belt is not twisted.
- 5) Check the routing of the motion drive belt. Make sure the motion drive belt is installed correctly on the idler pulley. Make sure the motion drive belt is inside all the belt guides.
- 6) Before you use the unit, check the adjustment of the clutch. See the instructions "How To Check And Adjust The Clutch".
- 7) Install the mower housing. See the instructions "How To Install The Mower Housing".

7.21 HOW TO INSTALL THE WHEELS

If the wheels must be removed for service, make sure they are installed as follows.

Front Wheel

- 1) Make sure the valve stem is to the outside of the tractor. Slide the front wheel on the spindle.
- 2) Fasten the front wheel with washer and cotter pin. Bend the ends of the cotter pin apart to keep the front wheel on the spindle.
- 3) If your model has hub caps, install the hub caps. Make sure the washer hold the hub caps in place.

Rear Wheel

Please refer to **Assembly-Rear Wheel**.

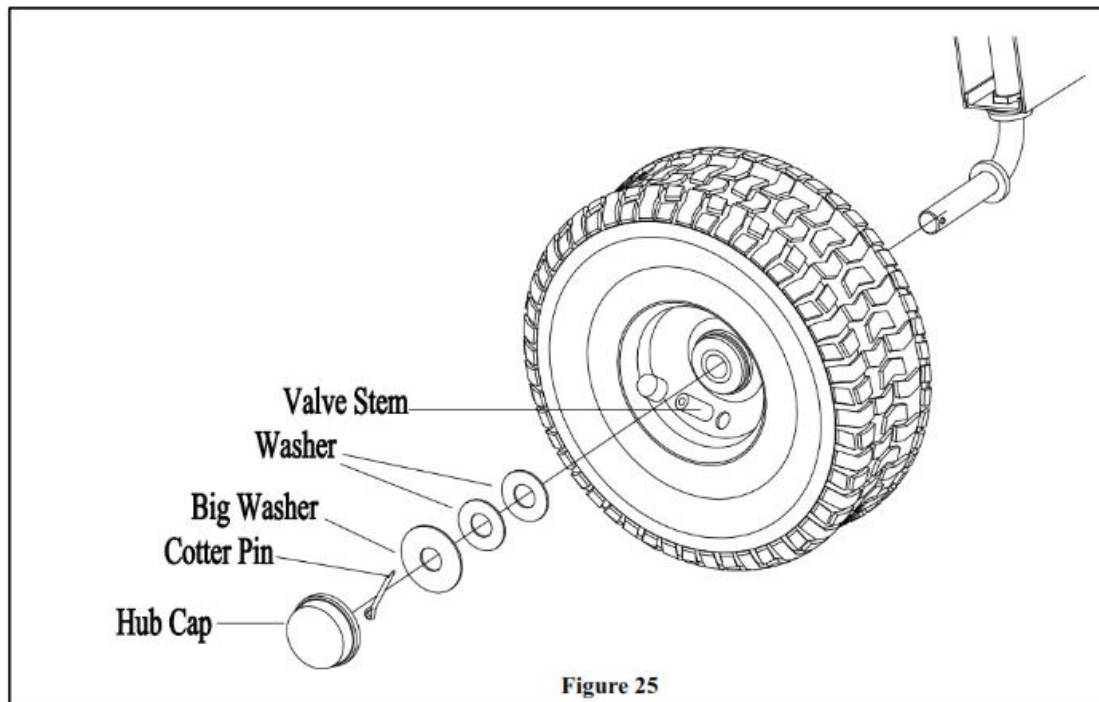

Figure 25

7.22 HOW TO REPLACE THE FUSE

If the fuse is blown, the engine will not start. The location of the fuse is next to the battery. Remove the fuse and replace with a automotive fuse.

7.23 HOW TO CLEAN THE MOWER HOUSING

WARNING: Before you clean the mower housing, stop the engine and disconnect the wire to the spark plug.

Grass and other debris on top of the mower housing can keep the belt from working correctly. For safety and correct operation, frequently clean the top of the mower housing. Remove grass and debris from around the pulleys and other moving parts.

- 1) Move the lever for the blade rotation control to the **ENGAGE** position.
- 2) Clean the top of the mower housing.
- 3) Move the lever for the blade rotation control to the **DISENGAGE** position.
- 4) Again clean the top of the mower housing.
- 5) After you cut the grass, clean the bottom of the mower housing.

7.24 STORAGE (OVER 30 DAYS)

At the end of each year, prepare the unit for storage as follows.

The Engine

For storage information, see the the engine manufacturer's instructions.

The Battery

- 1) Remove the battery.
- 2) Clean the battery terminals of any deposits.
- 3) Store the battery in a cool, dry place.

NOTE: After a long time in storage, charge the battery.

The Fuel System

WARNING: Do not drain the gasoline inside a building or near a fire. Do not smoke because the fumes

from the fuel can cause an explosion.

1. Start the engine.
2. Run the engine until the fuel tank and the carburetor are out of fuel and the engine stops.
3. After storage, make sure you use fresh fuel.

Clean The Unit

1. Clean the dirt and grass from the engine.
2. Clean the mower housing.

Lubricate The Unit

See the "Lubrication" instructions in this book.

8. TROUBLESHOOTING

PROBLEM: The engine will not start.

- 1) Follow the steps in "**Starting The Mower**" in this book
- 2) Electric Start Models: Clean the battery terminals. Tighten the cables.
- 3) Drain the fuel tank. Clean the fuel line.
- 4) Remove the spark plug. Move the throttle to the **SLOW** position. Turn the ignition key to the **ON** position. Try to start the engine several times. Install the spark plug.
- 5) Replace the spark plug.
- 6) Adjust the carburetor.

PROBLEM: The engine will not turn over.

- 1) Follow the steps in "**Starting The Mower**" in this book.
- 2) Electric Start Models: Check the power of battery. If needed, start the mower manually.
- 3) Replace the fuse.
- 4) Check the wiring harness for damage or a loose connection. Repair the damaged wire.

PROBLEM: The engine is difficult to start.

- 1) Adjust the carburetor.
- 2) Replace the spark plug.
- 3) Replace the fuel filter.

PROBLEM: The engine does not run smooth or has a loss of power.

- 1) Check the oil.
- 2) Clean the air filter.
- 3) Clean the air screen.
- 4) Replace the spark plug.
- 5) The engine is working too hard. Use a lower gear.
- 6) Adjust the carburetor.
- 7) Replace the fuel filter.

PROBLEM: The engine does not run smooth at fast speed.

- 1) Replace the spark plug.
- 2) Adjust the throttle control.
- 3) Clean the air filter.
- 4) Replace the fuel filter.

PROBLEM: The engine stops when the blades are engaged.

- 1) To activate the seat sensor, always sit in the middle of the seat.
- 2) Check the wiring harness for damage or a loose connection. Repair the damaged wire.
- 3) Check grass catcher switch.

PROBLEM: On slopes, the engine stops.

- 1) Mow up and down slopes. Never mow across a slope.
- 2) To activate the seat sensor, always sit in the middle of the seat.

PROBLEM: The engine will not idle.

- 1) Replace the spark plug.
- 2) Clean the air filter.
- 3) Adjust the carburetor.
- 4) Adjust the throttle control.
- 5) Drain the fuel tank. Clean the fuel line. Replace the fuel filter.

PROBLEM: A hot engine causes a decrease in power.

- 1) Clean the air screen.

- 2) Check the oil.
- 3) Adjust the carburetor.
- 4) Replace the fuel filter.

PROBLEM: Excessive vibration.

- 1) Replace the blade.
- 2) Check for loose engine bolts.
- 3) Decrease the air pressure in the tires.
- 4) Adjust the carburetor.
- 5) Check for a damaged belt or damaged pulley. Replace the damaged parts.

PROBLEM: The grass does not discharge correctly.

- 1) Stop the engine. Clean the mower housing.
- 2) Raise the height of cut.
- 3) Replace or sharpen the blade(s).
- 4) Move the shift lever to a slower speed.
- 5) Move the throttle control to the **FAST** position.
- 6) Replace the spring for the blade idler.

PROBLEM: The mower housing does not cut level.

- 1) Check the air pressure in the tires.
- 2) Adjust the level of the mower housing.
- 3) Check the front axle. If the front axle does not freely pivot, loosen the axle bolt(s).

PROBLEM: The mower blades will not rotate.

- 1) Check the mower drive belt. Make sure the belt is installed correctly.
- 2) Replace the mower drive belt.

PROBLEM: The unit will not move when the clutch is engaged.

- 1) Check the motion drive belt. Make sure the belt is installed correctly.
- 2) Adjust the clutch.
- 3) Replace the motion drive belt.

PROBLEM: The unit moves slower or stops when the clutch is engaged.

- 1) Adjust the clutch.
- 2) Replace the motion drive belt.

PROBLEM: When the clutch/brake pedal is released, belt noise can be heard.

- 1) Temporary belt noise does not change the operation of the unit if belt noise is continuous, check the routing of the belt. Make sure the belt is inside all belt guides.
- 2) If the noise is continuous, adjust the clutch.

PROBLEM: The rear wheels spin over uneven terrain.

- 1) Check the front axle. If the front axle does not freely pivot. loosen the axle bolt(s)

PROBLEM: The transaxle is difficult to shift between gears with the engine running and the clutch depressed.

- 1) Check the clutch adjustment to make sure the belt stops when the clutch pedal is depressed with the transaxle in (N) neutral.
- 2) Check the belt guides around the transaxle drive pulley. Make sure the belt guides do not touch the pulley.

9. DECLARATION OF CONFORMITY



BUILDER SAS

32 rue Aristide Bergès - Z.I. du Casque - 31270 Cugnaux - France
Tel. +33 (0) 5.34.502.502 Fax: +33 (0) 5.34.502.503

Declares that the machine named below

Petrol lawn mower rider
RAC6625PR / RAC6625SDPR
Serial number: 20240408625-20240408638
20240408639-20240408651

Complies with the following European Directives:

Machinery Directive 2006/42/EC
EMC Directive 2014/30/EU
Emission Regulation (EU) 2016/1628 amended by regulation 2018/989

Applicable harmonized standards:

EN ISO 5395-1: 2013+A1:2018
EN ISO 5395-3: 2013+A1:2017+A2:2018
EN ISO 14982: 2009

Other applicable guidelines:

Noise Directive 2000/14/EC amended by 2005/88/EC, Annex VI

Guaranteed Sound Power Level	98dB(A)
Sound power level	L _{wA} : 95,5dB(A) K= 2,37dB(A)

Noise notified body number: 0036

TÜV SÜD Industrie Service GmbH • Westendstrasse 199 • 80686 München • Deutschland

EU type-approval No: e9*2016/1628*2016/1628SYA1/P*1352*00

Cugnaux, 03/03/2024

Philippe MARIE / CEO

Responsible of technical file: M. Olivier Patriarca

10. WARRANTY

The manufacturer guarantees the product against defects in material and workmanship for a period of 5 years from the date of the original purchase. The warranty only applies if the product is for household use. The warranty does not cover breakdowns due to normal wear and tear.

The manufacturer agrees to replace parts identified as defective by the designated distributor. The manufacturer does not accept responsibility for the replacement of the machine, in whole or in part, and/or ensuing damage.

The warranty does not cover breakdowns due to:

- Insufficient maintenance.
- Abnormal assembly, adjustment or operations of the product.
- Parts subject to normal wear and tear.

The warranty does not extend to:

- Shipping and packaging costs.
- Using the tool for a purpose other than that for which it was designed.
- The use and maintenance of the machine done in a manner not described in the user manual.

Due to our policy of continuous product improvement, we reserve the right to alter or change specifications without notice. Consequently, the product may be different from the information contained therein, but a modification will be undertaken without notice if it is recognized as an improvement of the preceding characteristic.

READ THE MANUAL CAREFULLY BEFORE USING THE MACHINE.

When ordering spare parts, please indicate the part number or code, you can find this in the spare parts list in this manual. Keep the purchase receipt; without it, the warranty is invalid. To help you with your product, we invite you to contact us by phone or via our website:

+33 (0)9.70.75.30.30

<https://services.swap-europe.com/contact>

You must create a "ticket" via the web platform.

- Register or create your account.
- Indicate the reference of the tool.
- Choose the subject of your request.
- Describe your problem.
- Attach these files: invoice or sales receipt,

photo of the identification plate (serial number),

photo of the part you need (for example:

pins on the transformer plug which are broken).



11. PRODUCT FAILURE

WHAT TO DO IF MY MACHINE BREAKS DOWN?

If you bought your product in a store:

- Empty the fuel tank.
- Make sure that your machine is complete with all accessories supplied, and clean! If this is not the case, the repairer will refuse the machine.
- Go to the store with the complete machine and with the receipt or invoice.

If you bought your product on a website:

- Empty the fuel tank.
- Make sure that your machine is complete with all accessories supplied, and clean! If this is not the case, the repairer will refuse the machine.
- Create a SWAP-Europe service ticket on the site: <https://services.swap-europe.com> When making the request on SWAP-Europe, you must attach the invoice and the photo of the nameplate (serial number).

Contact the repair station to make sure it is available before dropping off the machine.

Go to the repair station with the complete machine packed, accompanied by the purchase invoice and the station support sheet downloadable after the service request is completed on the SWAP-Europe site

For machines with engine failure from manufacturers BRIGGS & STRATTON, HONDA and RATO, please refer to the following instructions.

Repairs will be done by approved engine manufacturers of these manufacturers, see their site:

- <http://www.briggsandstratton.com/eu/fr>
- <http://www.honda-engines-eu.com/fr/service-network-page;jsessionid=5EE8456CF39CD572AA2AEEDFD290CDAE>
- <https://www.rato-europe.com/it/service-network>

Please keep your original packaging to allow for after-sales service returns or pack your machine with a similar cardboard box of the same dimensions.

For any question concerning our after-sales service you can make a request on our website <https://services.swap-europe.com>

Our hotline remains available at +33 (9) 70 75 30 30.



12. WARRANTY EXCLUSIONS

THE WARRANTY DOES NOT COVER:

- Start-up and setting up of the product.
- Damage resulting from normal wear and tear of the product.
- Damage resulting from improper use of the product.
- Damage resulting from assembly or start-up not in accordance with the user manual.
- Breakdowns related to carburetion beyond 90 days and fouling of carburetors.
- Periodic and standard maintenance events.
- Actions of modification and dismantling that directly void the warranty.
- Products whose original authentication marking (brand, serial number) has been degraded, altered or withdrawn.
- Replacement of consumables.
- The use of non-original parts.
- Breakage of parts following impacts or projections.
- Accessories breakdowns.
- Defects and their consequences linked to any external cause.
- Loss of components and loss due to insufficient screwing.
- Cutting components and any damage related to the loosening of parts.
- Overload or overheating.
- Poor power supply quality: faulty voltage, voltage error, etc.
- Damages resulting from the deprivation of enjoyment of the product during the time necessary for repairs and more generally the costs related to the immobilization of the product.
- The costs of a second opinion established by a third party following an estimate by a SWAP-Europe repair station
- The use of a product which would show a defect or a breakage which was not the subject of an immediate report and/or repair with the services of SWAP-Europe.
- Deterioration linked to transport and storage*.
- Launchers beyond 90 days.
- Oil, petrol, grease.
- Damages related to the use of non-compliant fuels or lubricants.

* In accordance with transport legislation, damage related to transport must be declared to carriers within 48 hours maximum after observation by registered letter with acknowledgement of receipt. This document is a supplement to your notice, a non-exhaustive list.

Attention: all orders must be checked in the presence of the delivery person. In case of refusal by the delivery person, it you must simply refuse the delivery and notify your refusal.

Reminder: the reserves do not exclude the notification by registered letter with acknowledgement within 72 hours.

Information: Thermal devices must be wintered each season (service available on the SWAP-Europe site). Batteries must be charged before being stored.



BUILDER SAS
32, rue Aristide Bergès - ZI 31270 Cugnaux – France
Made in PRC 2024